

General Instruments

Scalpel Handles



No. 3

4-0005-03



No. 3

4-0007-03



No. 4

4-0011-04



No. 4

4-0013-04



No. 7

4-0017-07



No. 7k

4-0019-17



Collin

No. 8
4-0023-08



Collin

No. 9
4-0027-09



double handle
number 3 + number 4

4-0031-34

General Instruments

Scalpel Handles

4



3L
4-0035-13



4L
4-0039-14



No. 3L
4-0043-03



No. 4L
4-0047-04



No. 5
4-0051-05
15cm/6"



No. 5A
4-0053-15
15cm/6"



4-0057-01
21cm/8 1/4"



4-0057-03



17cm/6¾"



Fig. 1
4-0062-01



Fig. 2
4-0062-02



Fig. 3
4-0062-03



Fig. 4
4-0062-04



Fig. 5
4-0062-05



Fig. 6
4-0062-06



Fig. 7
4-0062-07



Fig. 8
4-0062-08



Fig. 9
4-0062-09



Fig. 10
4-0062-10



Fig. 1
4-0066-01



Fig. 2
4-0066-02



Fig. 3
4-0066-03



Fig. 4
4-0066-04



Fig. 5
4-0066-05



Fig. 6
4-0066-06



Fig. 7
4-0066-07



Fig. 8
4-0066-08



Fig. 9
4-0066-09



17cm/6 $\frac{3}{4}$ "



Fig. 10
4-0066-10



Fig. 11
4-0066-11



Fig. 12
4-0066-12



Fig. 13
4-0066-13



Fig. 14
4-0066-14



Fig. 15
4-0066-15



Fig. 16
4-0066-16



Fig. 18
4-0066-18



Fig. 27
4-0066-27



Fig. 38
4-0066-38



Fig. 40
4-0066-40



Fig. 46
4-0066-46



Fig. 61
4-0066-61



Fig. 63
4-0066-63



Dieffenbach
17cm/6 3/4"



Fig. 1
4-0070-01



Fig. 2
4-0070-02



Fig. 3
4-0070-03



Fig. 4
4-0070-04



Fig. 5
4-0070-05



Fig. 6
4-0070-06



Fig. 7
4-0070-07



Fig. 8
4-0070-08



Fig. 9
4-0070-09



Fig. 15
4-0070-15



Fig. 16
4-0070-16



← Fig. 1

Bergmann
4-0074-01
14.5cm/5¾"



Fig. 2
4-0074-02



Fig. 3
4-0074-03



Fig. 4
4-0074-04



Dieffenbach
13cm/5¼"



Fig. 1
4-0078-01



Fig. 2
4-0078-02



Fig. 3
4-0078-03



Fig. 4
4-0078-04



Fig. 5
4-0078-05



Fig. 6
4-0078-06



Fig. 7
4-0078-07



Fig. 8
4-0078-08



Fig. 9
4-0078-09



Fig. 10
4-0078-10



Fig. 11
4-0078-11



Fig. 12
4-0078-12



Simon
20cm/8"



Fig. 1
13-01432-01



Fig. 2
13-01432-02



Fig. 3
13-01432-03



Fig. 4
13-01432-04



Ulrich
22.5 cm/9"



Fig. 1
13-01436-01



Fig. 2
13-01436-02



Fig. 3
13-01436-03



Simon
23.5 cm/9 1/4"



Fig. 1
13-01440-01



Fig. 2
13-01440-02



Fig. 3
13-01440-03



Fig. 4
13-01440-04



13-01444-01
7.5 cm/3"



13-01444-02
8 cm/3 1/4"

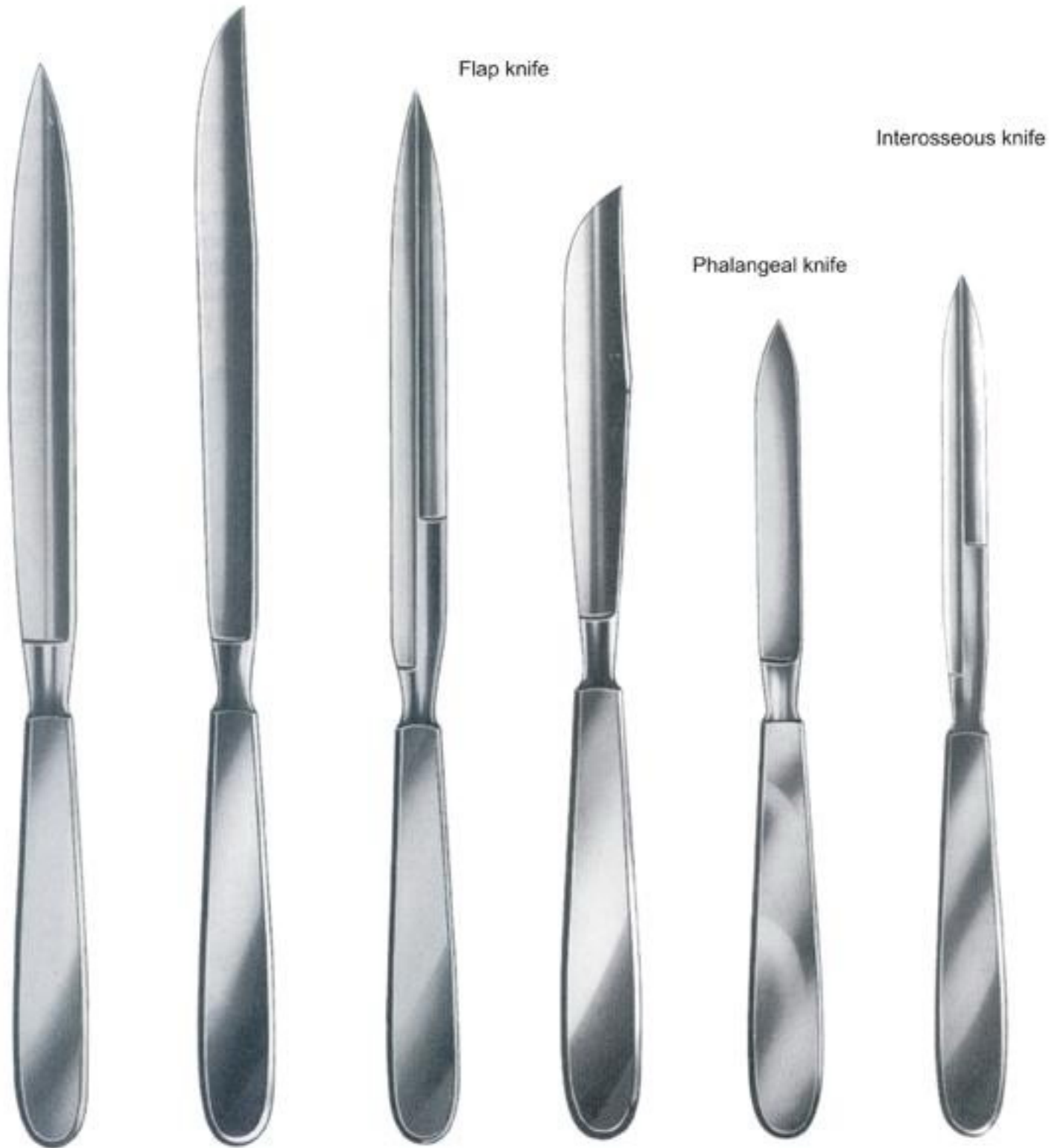

Length of blades		Liston	Catlin	Langenbeck	Flap knife	Phalangeal knife	Interosseous knife
cm	in						
9.5	3 3/4						5-0020-09
11.0	4 1/2						5-0024-11
12.0	4 3/4					5-0016-12	
13.0	5	5-0004-13					
15.0	6						
16.0	6 1/4	5-0004-16		5-0012-16			
17.0	6 3/4		5-0008-17				
19.0	7 1/2	5-0004-19		5-0012-19			
20.0	8		5-0008-20				
22.0	8 3/4	5-0004-22		5-0012-22			

Resection knives



5-0028-02

Langenbeck
5-0028-01
18 cm/7"



Walb

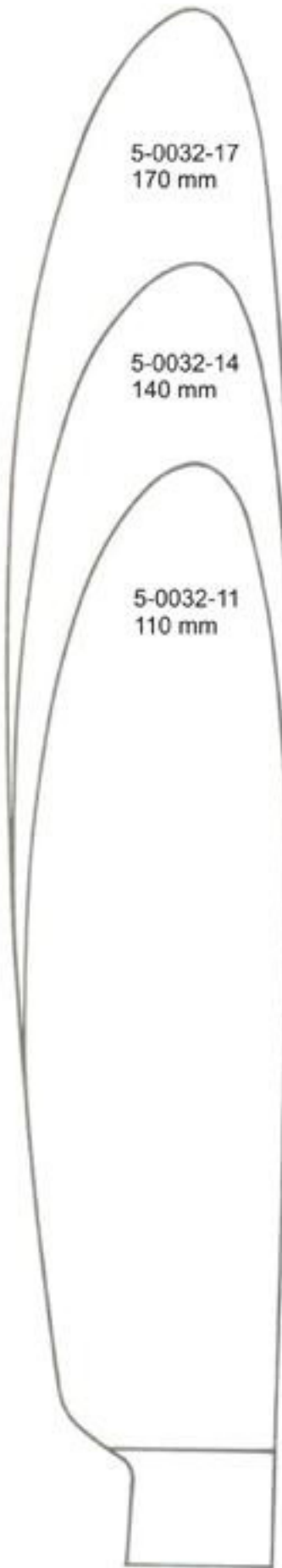

5-0032-17
170 mm

5-0032-14
140 mm

5-0032-11
110 mm



Virchow



5-0036-24
38.240 mm

5-0036-20
28.200 mm

5-0036-16
21.160 mm

Length of blades

11.0 cm/4 1/2"	5-0032-11	
14.0 cm/5 1/2"	5-0032-14	
16.0 cm/6 1/4"		5-0036-16
17.0 cm/6 3/4"	5-0032-17	
20.0 cm/8"		5-0036-20
24.0 cm/9 1/2"		5-0036-24



5-0040-17
17,5 cm/7"



5-0044-17
17,5 cm/7"



Virchow
5-0048-22
22 cm/8 1/2"
90 mm



Virchow
5-0052-22
22 cm/8 1/2"
90 mm



5-0056-22
21 cm/8 1/4"
70 mm



Virchow
5-0060-25
25cm/10"



Virchow
5-0064-25
25cm/10"



Virchow
5-0068-25
25cm/10"
95 mm



Virchow
5-0072-26
26cm/10¼"
90 mm



Virchow
5-0076-26
26cm/10¼"
120 mm



Virchow
5-0080-27
27cm/10½"
150 mm



Virchow
5-0084-00
15 mm



Skull Breaker

5-0086-14
14 cm/5½"



Rachiotome

5-0090-22
22 cm/8¾"

23 mm



Osteotome

5-0094-13
13 cm/5"



Brunetti
5-0098-28



Brunetti
5-0100-28

28.5 cm/11¼"



5-0104-27
27 cm/10½"

General Instruments

Blow Pipes and Post Mortem Set

5



5-0108-07
7 cm



5-0110-06
6,5 cm



5-0112-10
10,5 cm



5-0116-00



5-0120-00



5-0120-05



5-0124-00

5-0124-00

Post mortem set in wooden case.

Consisting of:

- 2 Dissecting knives. 4-0066-03
- 1 Dissecting knife. 4-0066-07
- 1 post mortem knife. 5-0064-25
- 1 Cartilage knife. 5-0044-17
- 1 Scissors with probe-end, straight,
13 cm long (5 1/8") 7-0125-13
- 1 Dressing forceps,
13 cm long (5 1/8") 8-0005-13
- 1 Charrier 30 cm/12" 15-1110-30
- 1 Metal hammer. 15-1332-30
- 1 Osteotome. 5-0094-13
- 2 Dissecting hooks, double, 5-0110-08
- 2 Blow pipes, double, 5-0120-05
- 2 Probes with olive-ends,
13 cm long (5") 12-0008-13
- 3 suture needles, assorted sizes.



Thiersch
5-0125-20
20 cm/8"



Humby
5-0129-30
30 cm/12"



Spare blade
5-0129-00



Schink
5-0133-30
30 cm/12"



Spare blade
5-0133-00

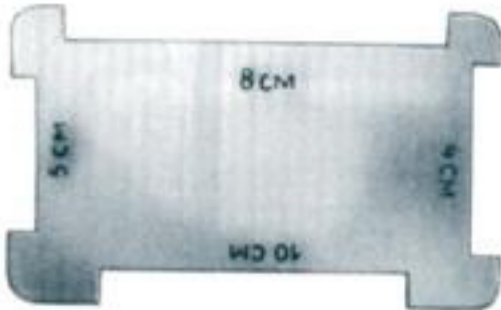

5-0137-00



Troutman-Chris
5-0141-09
9cm/3 1/2"



Troutman-Chris
5-0145-09
9cm/3 1/2"



5-0149-11
11cm/4 1/2"



Castroviejo
5-0153-13
13cm/5 1/4"



5-0157-18
18cm/7"



- 6-0005-08
 Dissecting scissors 11cm/4 1/2" 7-1121-11
 1 13cm/5" 7-1121-13
 1 Needle curved
 1 Straight
 1 Dissecting forceps 13cm/5" 8-0025-13
 Fine points
 1 Broad 13cm/5" 8-0037-13
 1 B.P. Handle #4 4-0011-04
 1 Pkt Surgical blades #22



- 6-0010-09
 1 Operating scissors SH/BL straight 14.5cm/5 3/4" 7-0149-14
 1 curved 7-0168-14
 1 Dressing forceps fine point 14.5cm/5 3/4" 8-0025-14
 1 Broad point 14.5cm/5 3/4" 8-0005-14
 1 B. P. Handle #3 4-0005-03
 1 #4 4-0011-04
 1 Mayo handle needle holders B/J 16cm/6 1/4" 13-0206-16
 1 Director tongue tie 14cm/5 1/2" 12-0028-14
 1 Probe D/End 14cm/5 1/2" 12-0008-14



6-0015-05
 Dissecting set
 in plastic case, consisting
 1 Dissecting knife 4-0062-03
 1 Scissors, curved, 4-1122-11
 1 Microscopic forceps,
 10.5 cm long(4 1/4") 24-0894-10
 2 Dissecting needles

6-0015-10
 Dissecting set
 in plastic case, consisting of:
 1 Dissecting knife 4-0062-03
 1 Dissecting knife 4-0062-05
 1 Dissecting knife 4-0062-08
 1 Probe, Olive ends, 13 cm long (5") 12-0016-13
 1 Grooved Director, 13 cm long (5") 12-0028-13
 1 Dissecting hook, double 5-0112-10
 1 Scissors with probe-end, 13cm long (5 1/8") 7-0215-13
 1 Dressing forceps,
 13 cm long(5") 8-0005-13
 1 Blow pipe, double 5-0120-05

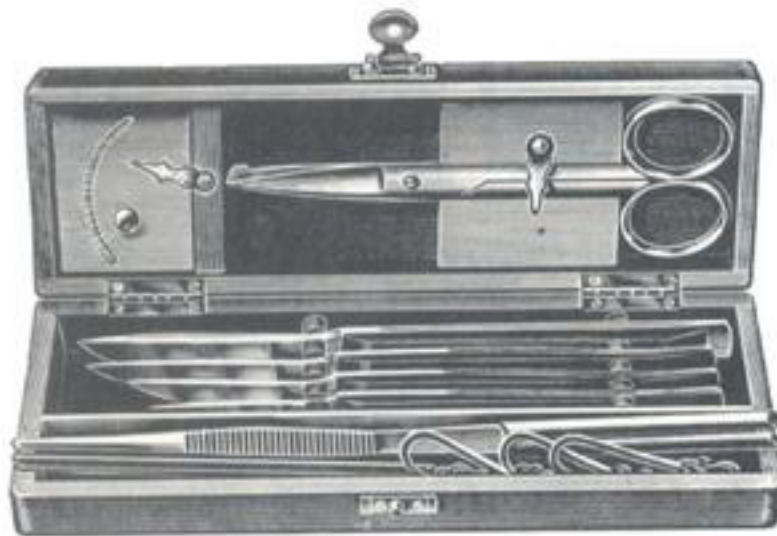

6-0020-13
 Dissecting set
 in wooden case, consisting of:
 1 Dissecting knife 4-0062-03
 1 Dissecting knife 4-0062-08
 1 Cartilage knife 4-0060-25
 1 Scissors with probe-end,
 13 cm long (5") 7-0215-13
 1 Dressing forceps,
 13 cm long (5") 8-0005-13
 1 Tissue forceps,
 13 cm long (5") 8-0179-13
 1 Microscopic forceps,
 10.5 cm long (4 1/4")
 1 Probe with eye,
 13 cm long (5") 12-0016-13
 1 Dissecting hook, double 5-0110-08

6-0020-15
 Dissecting set
 in wooden case, consisting of:
 1 Dissecting knife 4-0062-03
 1 Dissecting knife 4-0062-05
 1 Dissecting knife 4-0062-08
 1 Cartilage knife 5-0060-25
 1 Scissors with probe-end,
 13 cm long (5") 7-0215-13
 1 Dressing forceps,
 13 cm long (5") 8-0005-13
 1 Triple chain hook 5-0116-00
 1 Blow pipe, double 5-0120-05

Saw Edge



Straight	Curved
7-0005-14	7-0006-14
14.5cm/5¾"	



Mayo	
Straight	Curved
7-0011-14	7-0012-14
7-0011-17	7-0012-17
7-0011-23	7-0012-23
14.5cm/5¾"	17.0cm/6¾"
17.0cm/6¾"	23.0cm/9"



Mayo-Stille	
Straight	Curved
7-0017-15	7-0018-15
7-0017-17	7-0018-17
15.0cm/6"	17.0cm/6¾"



Lexer	
Straight	Curved
7-0023-16	7-0024-16
16cm/6¼"	



Baby-Metzenbaum	
Straight	Curved
7-0029-11	7-0030-11
11.5cm/4½"	



Metzzenbaum	
Straight	Curved
7-0035-14	7-0036-14
14.5cm/5¾"	



Metzzenbaum-Fine	
Straight	Curved
7-0041-14	7-0042-14
7-0041-18	7-0042-18
7-0041-20	7-0042-20
7-0041-23	7-0042-23
14cm/5¾"	18cm/7"
20cm/8"	23cm/9"

Saw edge



Sims

Straight		Curved
7-0047-20	20 cm/8"	7-0048-20
7-0047-23	23 cm/9"	7-0048-23



Siebold

7-0052-24
24 cm/9½"



Jameson

7-0056-15 15 cm/6"
7-0056-18 18 cm/7"



Reynolds

Straight	Curved
7-0061-15	7-0062-15
	15 cm/6"



Straight	Curved
7-0067-11	7-0068-11
	11.5 cm/4½"



Straight	Curved
7-0073-11	7-0074-11
	11.5 cm/4½"



Plastic Surgery

Straight	Curved
7-0079-12	7-0080-12
	12 cm/4¾"



Wagner

Straight	Curved
7-0085-12	7-0086-12
	12 cm/4¾"

Saw Edge



7-0090-11
11.5 cm/4½"



7-0094-14
14cm/5½"



Reynolds
7-0098-13
13cm/5"

Endarterectomy
Scissors



Potts-Smith
19cm/7½"



25°
7-0102-19



45°
7-0104-19



60°
7-0106-19



7-0110-17
17cm/6¾"

Saw Edge



Lister
 7-0115-14 14.5cm/5¾"
 7-0115-18 18cm/7"
 7-0115-20 20cm/8"



Braun-Stadler
 7-0119-14 14.5cm/5¾"
 7-0119-22 22cm/8¾"



Stevens
 Straight 7-0123-11 11.5cm/4½"
 Curved 7-0124-11



Heymann
 7-0129-18
 18cm/7"



Fomon
 7-0134-13
 13cm/5"



Fomon
 7-0139-13
 13cm/5"



Cottle
 7-0143-16
 16cm/6¼"



Straight

Standard
Fig. 1



Straight

Standard
Fig. 2



Straight

Standard
Fig. 3

10.0	cm/4"	7-0147-10
11.5	cm/4½"	7-0147-11
13.0	cm/5"	7-0147-13
14.5	cm/5¾"	7-0147-14
15.5	cm/6"	7-0147-15
16.0	cm/6¼"	7-0147-16
18.0	cm/7"	7-0147-18
20.0	cm/8"	7-0147-20

7-0149-10
7-0149-11
7-0149-13
7-0149-14
7-0149-15
7-0149-16
7-0149-18
7-0149-20

7-0153-10
7-0153-11
7-0153-13
7-0153-14
7-0153-15
7-0153-16
7-0153-18
7-0153-20



Straight

Standard
14.5cm/5¾"



Fig. 1
7-0157-14



Fig. 2
7-0159-14



Fig. 3
7-0161-14



Curved



Curved



Curved

	Standard Fig. 1
10.0 cm/4"	7-0166-10
11.5 cm/4½"	7-0166-11
13.0 cm/5"	7-0166-13
14.5 cm/5¾"	7-0166-14
15.5 cm/6"	7-0166-15
16.0 cm/6¼"	7-0166-16
18.0 cm/7"	7-0166-18
20.0 cm/8"	7-0166-20

	Standard Fig. 2
10.0 cm/4"	7-0168-10
11.5 cm/4½"	7-0168-11
13.0 cm/5"	7-0168-13
14.5 cm/5¾"	7-0168-14
15.5 cm/6"	7-0168-15
16.0 cm/6¼"	7-0168-16
18.0 cm/7"	7-0168-18
20.0 cm/8"	7-0168-20

	Standard Fig. 3
10.0 cm/4"	7-0170-10
11.5 cm/4½"	7-0170-11
13.0 cm/5"	7-0170-13
14.5 cm/5¾"	7-0170-14
15.5 cm/6"	7-0170-15
16.0 cm/6¼"	7-0170-16
18.0 cm/7"	7-0170-18
20.0 cm/8"	7-0170-20

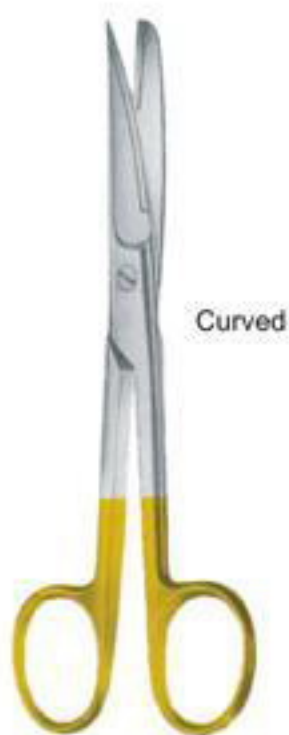

Curved

Standard
14.5cm/5¾"



Fig. 1
7-0174-14



Fig. 2
7-0176-14



Fig. 3
7-0178-14



Graziol



7-0183-13 13.0 cm/5"
 7-0183-14 14.5 cm/5¾"
Straight



7-0184-13
 7-0184-14



Graziol



7-0187-13 13.0 cm/5"
 7-0187-14 14.5 cm/5¾"
Curved



7-0188-13
 7-0188-14



Straight

7-0191-14

Deaver

14.5cm/5¾"



Curved

7-0192-14



Straight

7-0195-15

Mixer

15.5cm/6"



Curved

7-0196-15



Lexer
Straight
7-0199-16
16 cm/6 1/4"



Lexer
Curved
7-0200-16
16 cm/6 1/4"



Lexer
Straight
7-0203-16
16 cm/6 1/4"



Lexer
Curved
7-0204-16
16 cm/6 1/4"



Lexer-Fine
Straight
7-0207-16
16 cm/6 1/4"



Lexer-Fine
Curved
7-0208-16
16 cm/6 1/4"



Lexer-Fine
Straight
7-0211-16
16 cm/6 1/4"



Lexer-Fine
Curved
7-0212-16
16 cm/6 1/4"

Incision Scissors



7-0215-13 13.0 cm/5 1/4"
7-0215-14 14.5 cm/5 3/4"



7-0219-15
15.5 cm/6"



Richter
7-0224-14
14.5 cm/5 3/4"



Richter
7-0228-14
14.5 cm/5 3/4"



Fergusson
7-0232-18
18 cm/7"



New Suture
7-0236-14
14.5 cm/5 3/4"



Mayo
Straight
7-0241-14 14.5 cm/5 3/4"
7-0241-15 15.0 cm/6"
7-0241-17 17.0 cm/6 3/4"
7-0241-19 19.0 cm/7 1/2"
7-0241-23 23.0 cm/9"



Mayo
Curved
7-0242-14 14.5 cm/5 3/4"
7-0242-15 15.0 cm/6"
7-0242-17 17.0 cm/6 3/4"
7-0242-19 19.0 cm/7 1/2"
7-0242-23 23.0 cm/9"



Mayo
Straight
7-0245-14 14.5 cm/5 3/4"
7-0245-17 17.0 cm/6 3/4"
7-0245-23 23.0 cm/9"



Mayo
Curved
7-0246-14 14.5 cm/5 3/4"
7-0246-17 17.0 cm/6 3/4"
7-0246-23 23.0 cm/9"



Mayo-Stille
Straight
7-0251-15 15 cm/6"
7-0251-17 17 cm/6 3/4"
7-0251-19 19 cm/7 1/2"
7-0251-21 21 cm/8 1/4"



Mayo-Stille
Curved
7-0252-15 15 cm/6"
7-0252-17 17 cm/6 3/4"
7-0252-19 19 cm/7 1/2"
7-0252-21 21 cm/8 1/4"



Mayo-Stille
Straight
7-0255-15 15 cm/6"
7-0255-17 17 cm/6 3/4"



Mayo-Stille
Curved
7-0256-15 15 cm/6"
7-0256-17 17 cm/6 3/4"



Straight

Mayo-Noble
 7-0259-17
 17 cm/6¾"



Curved

Mayo-Noble
 7-0260-17
 17 cm/6¾"



Straight

Baby-Metzenbaum
 7-0263-11
 11.5 cm/4½"



Curved

Baby-Metzenbaum
 7-0264-11
 11.5 cm/4½"



Metzenbaum-Fine
 7-0267-14
 14.5 cm/5¾"



Metzenbaum-Fine
 7-0268-14
 14.5 cm/5¾"



Metzenbaum-Fine
 7-0271-14
 14.5 cm/5¾"



Metzenbaum-Fine
 7-0272-14
 14.5 cm/5¾"

Straight



Fig 1

Metzenbaum
7-0275-14
14.5 cm/5¾"



Fig 2

Metzenbaum
7-0277-14
14.5 cm/5¾"



Fig 3

Metzenbaum
7-0279-14
14.5 cm/5¾"

Straight

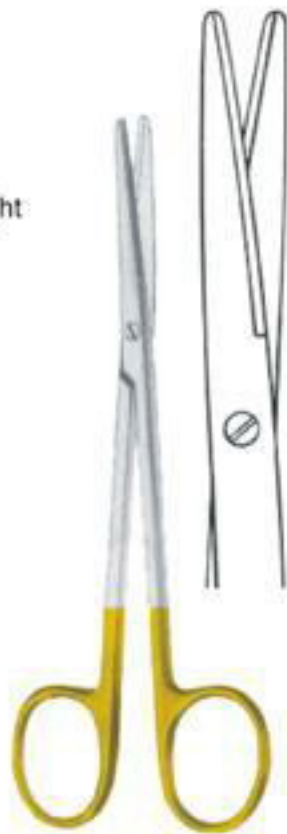

Metzenbaum
7-0283-14
14.5 cm/5¾"



Metzenbaum-Fine
7-0285-14
14.5 cm/5¾"



Metzenbaum-Fine
7-0287-14
14.5 cm/5¾"

Curved



Fig. 1
Metzenbaum
7-0292-14
14.5 cm/5¾"



Fig. 2
Metzenbaum
7-0294-14
14.5 cm/5¾"



Fig. 3
Metzenbaum
7-0296-14
14.5 cm/5¾"

Curved



Metzenbaum
7-0302-14
14.5 cm/5¾"



Metzenbaum-Fine
7-0304-14
14.5 cm/5¾"



Metzenbaum-Fine
7-0306-14
14.5 cm/5¾"

Straight



Metzenbaum-Fine

18 cm/7"	7-0311-18
20 cm/8"	7-0311-20
23 cm/9"	7-0311-23
25 cm/10"	7-0311-25
28 cm/11"	
30 cm/12"	



Metzenbaum

7-0313-18
7-0313-20
7-0313-23
7-0313-25
7-0313-28
7-0313-30



Metzenbaum

7-0315-18
7-0315-20
7-0315-23
7-0315-25
7-0315-28
7-0315-30



Metzenbaum

7-0317-18
7-0317-20
7-0317-23
7-0317-25
7-0317-28
7-0317-30

Straight



Metzenbaum

18 cm/7"	7-0322-18
20 cm/8"	7-0322-20
23 cm/9"	7-0322-23
25 cm/10"	7-0322-25
28 cm/11"	7-0322-28
30 cm/12"	7-0322-30



Metzenbaum-Fine

7-0324-18
7-0324-20
7-0324-23
7-0324-25



Metzenbaum-Fine

7-0326-18
7-0326-20
7-0326-23
7-0326-25

Curved



Metzenbaum-Fine

18 cm/7"	7-0331-18
20 cm/8"	7-0331-20
23 cm/9"	7-0331-23
25 cm/10"	7-0331-25
28 cm/11"	
30 cm/12"	



Metzenbaum

7-0333-18
7-0333-20
7-0333-23
7-0333-25
7-0333-28
7-0333-30



Metzenbaum

7-0335-18
7-0335-20
7-0335-23
7-0335-25
7-0335-28
7-0335-30



Metzenbaum

7-0337-18
7-0337-20
7-0337-23
7-0337-25
7-0337-28
7-0337-30

Curved



Metzenbaum

18 cm/7"	7-0341-18
20 cm/8"	7-0341-20
23 cm/9"	7-0341-23
25 cm/10"	7-0341-25
28 cm/11"	7-0341-28
30 cm/12"	7-0341-30



Metzenbaum-Fine

7-0343-18
7-0343-20
7-0343-23
7-0343-25



Metzenbaum-Fine

7-0345-18
7-0345-20
7-0345-23
7-0345-25



Sims
 7-0350-20 20 cm/8"
 7-0350-23 23 cm/9"



Straight
 7-0352-20 20 cm/8" 7-0354-20
 7-0352-23 23 cm/9" 7-0354-23



Sims
 7-0359-20 20 cm/8"
 7-0359-23 23 cm/9"



Curved
 7-0361-20 20 cm/8" 7-0363-20
 7-0361-23 23 cm/9" 7-0363-23



Sims
 7-0367-20 20 cm/8"
 7-0367-23 23 cm/9"



Wertheim
 7-0371-14 14.5 cm/5 3/4"
 7-0371-19 19.5 cm/7 3/4"
 7-0371-22 22.5 cm/9"



Curved

Dubois
7-0376-27 27 cm/10½"



Dubois
7-0377-27 27 cm/10½"



Straight

Doyen
7-0382-16 16 cm/6¼"
7-0382-18 18 cm/7"



Curved

Doyen
7-0383-16 16 cm/6¼"
7-0383-18 18 cm/7"



Kelly
7-0388-16 16 cm/6¼"
7-0388-18 18 cm/7"



Kelly
7-0389-16 16 cm/6¼"
7-0389-18 18 cm/7"



Fig. 1
7-0394-12



Fig. 2
7-0396-12

Straight

12cm/4¾"



Fig. 3
7-0398-12



Fig. 1
7-0403-12



Fig. 2
7-0405-12

Curved

12cm/4¾"



Fig. 3
7-0407-12

Saw Edge



Wagner
12cm/4¾"



Fig. 1
7-0410-12



Fig. 2
7-0412-12



Fig. 3
7-0414-12



Fig. 4
7-0416-12



Fig. 1
7-0411-12



Fig. 2
7-0413-12



Fig. 3
7-0415-12



Fig. 4
7-0417-12

Straight



7-0422-11
11.5cm/4½"

Curved



7-0423-11
11.5cm/4½"



Straight

Brophy (Sullivan)
7-0427-14

14.5 cm/5 3/4"



Curved

7-0428-14



Straight

Reynolds
7-0431-15
7-0431-18

15 cm/6"
18 cm/7"



Curved

7-0432-15
7-0432-18

Eucleation Scissors



Jameson
7-0436-15
15cm/6"



7-0444-12



7-0452-12



7-0454-12



7-0456-12

Landolt
12.5cm/5"

General Instruments

Fine Scissors

7



9.0 cm/3½"	7-0461-09	7-0462-09	7-0464-09	7-0469-09	Standard	7-0470-09
10.5 cm/4¼"	7-0461-10	7-0462-10	7-0464-10	7-0469-10		7-0470-10
11.5 cm/4½"	7-0461-11	7-0462-11	7-0464-11	7-0469-11		7-0470-11

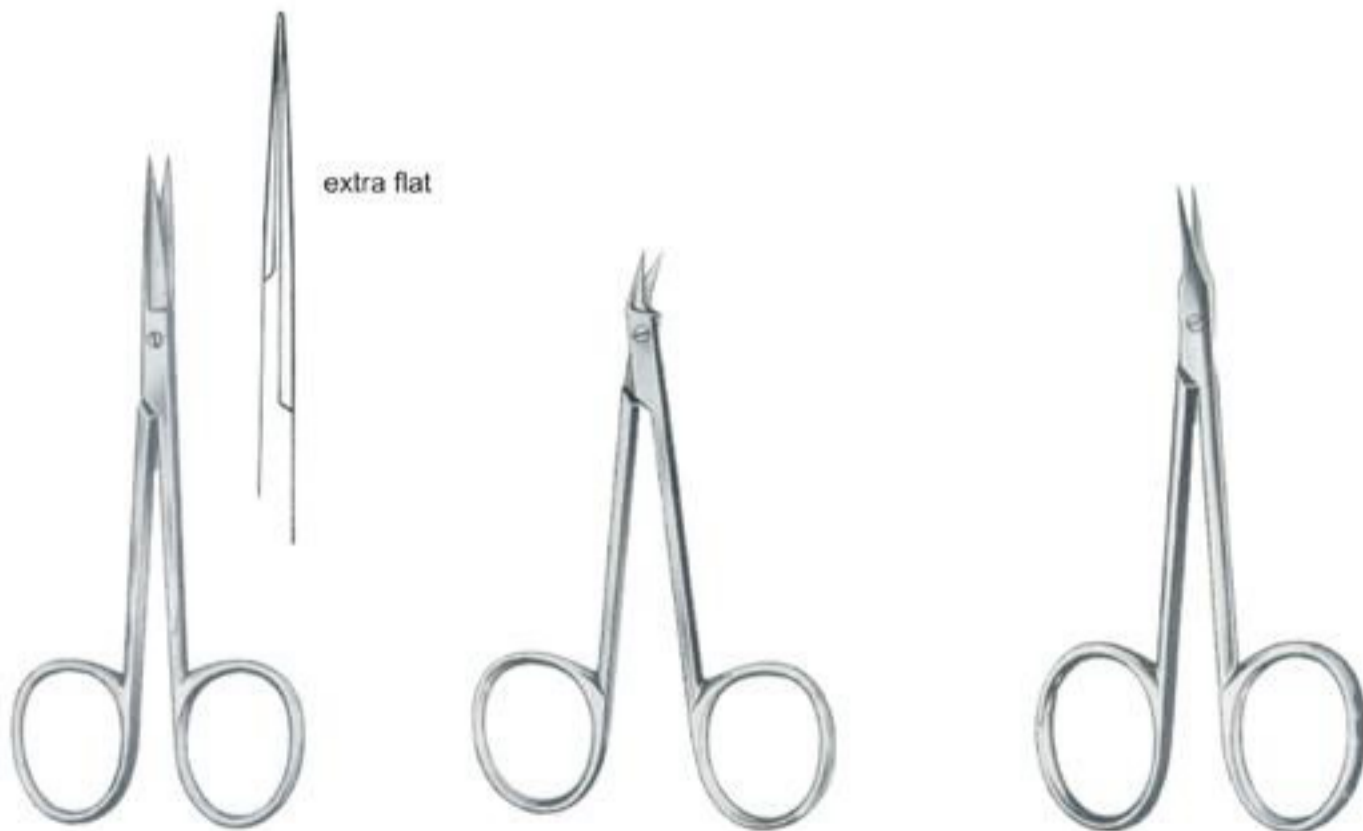

7-0475-10
10cm/4"

7-0479-09
9cm/3½"

Walton
7-0482-10
10cm/4"



Straight

7-0487-14

Sanvenero
14.5cm/5¾"



Curved

7-0488-14



Straight

7-0491-10

Baby-Lexer (Knapp)
10cm/4"



Curved

7-0492-10



Straight
7-0497-13

13cm/5"

Curved
7-0498-13



Straight

7-0503-14

Joseph
14cm/5½"



Curved

7-0504-14



Kilner (Ragnell)
7-0508-12 12cm/4³/₄"
7-0508-13 13cm/5"
7-0508-15 15cm/6"



7-0513-14
14.5cm/5³/₄"

Coronary Scissors



7-0517-11
11.5cm/4¹/₂"



Potts-Smith
7-0522-19
19.5cm/7³/₄"



De Bakey
7-0526-15
15.5cm/6"



De Bakey
7-0528-15
15.5cm/6"



Favaloro
7-0532-15
15cm/6"

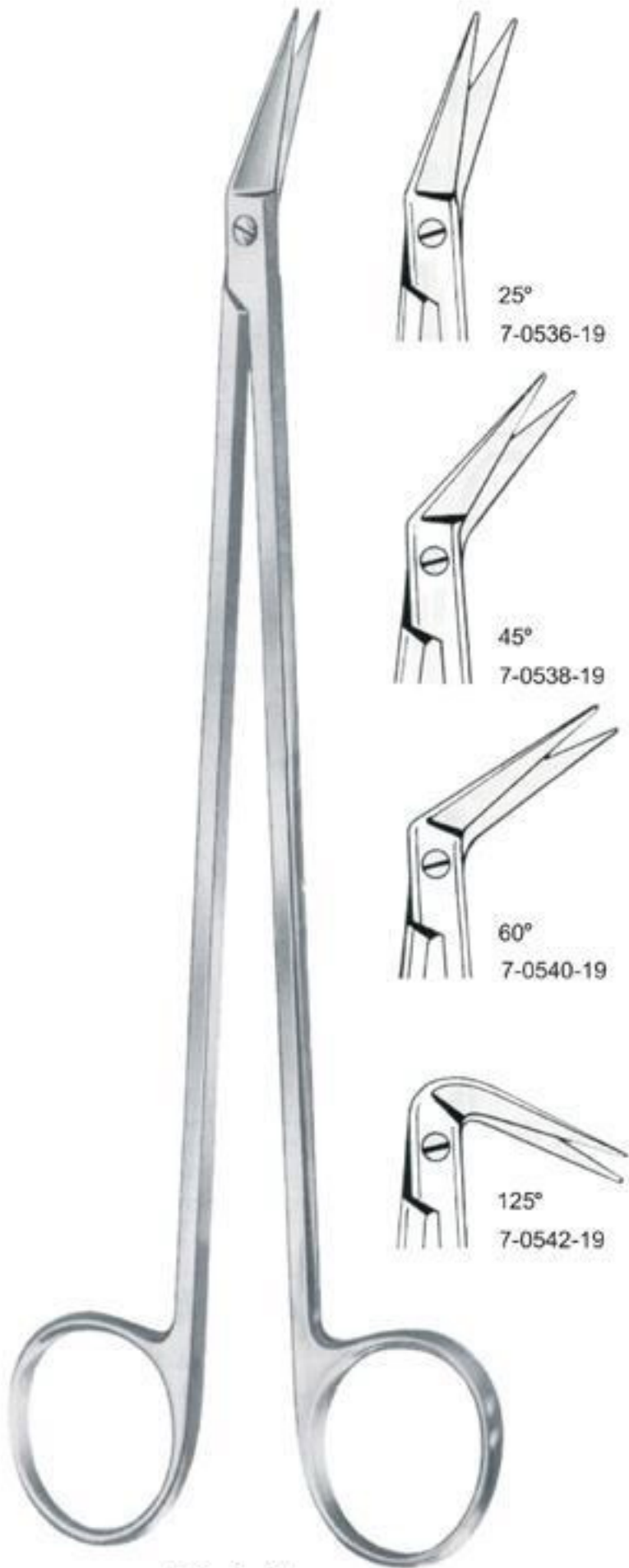

Potts-Smith
19cm/7½"

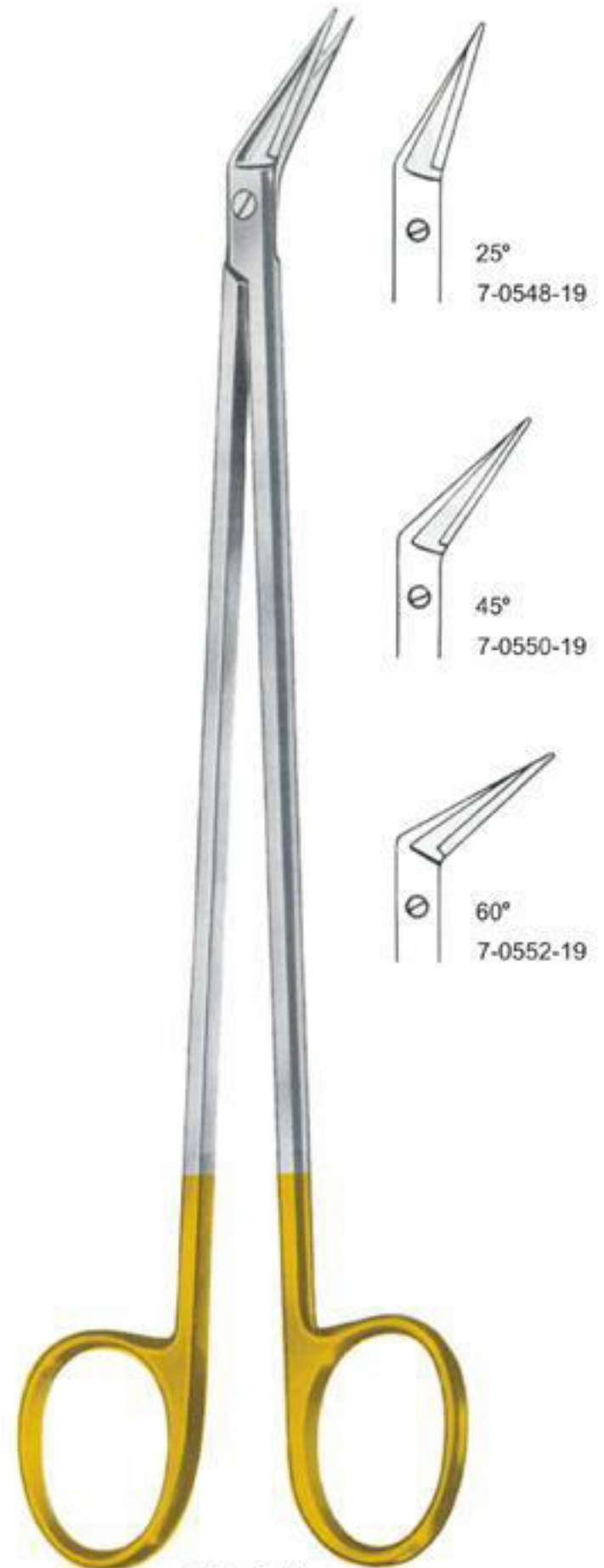

Potts-Smith
19cm/7½"



Saw Edge

Martin-Cartilage
7-0558-20
20cm/8"



McIndoe
7-0563-19
19cm/7½"



Potts-Smith
7-0568-19
19cm/7½"



Satinsky
7-0572-24
24.5cm/10"



Klingenberg-Loth
7-0576-23
23cm/9"



De Bakey
18cm/7"

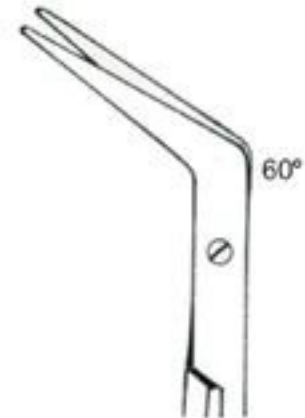
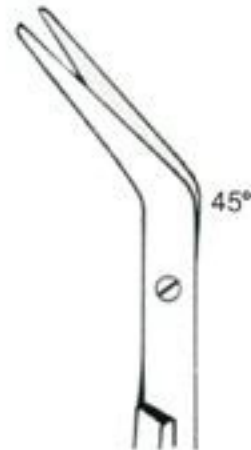
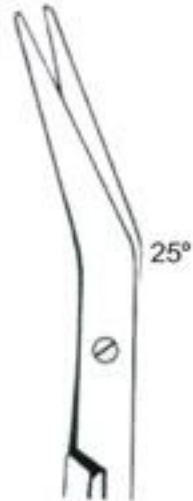

cm	In			
16.0cm	6 1/4"	7-0580-16	7-0582-16	7-0584-16
23.0cm	9"	7-0580-23	7-0582-23	7-0584-23
28.0cm	11"	7-0580-28	7-0582-28	7-0584-28



Baby-Hegemann
13.5cm/5 1/4"

Hegemann (Diethrich)
16cm/6 1/4"
19cm/7 1/2"



cm	In					
13.0cm	5 1/4"	7-0588-13	7-0590-13	7-0592-13	7-0594-13	7-0596-13
16.0cm	6 1/4"	7-0588-16	7-0590-16	7-0592-16	7-0594-16	7-0596-16
19.0cm	7 1/2"	7-0588-19	7-0590-19	7-0592-19	7-0594-19	7-0596-19



Hegemann (Diethrich)
7-0600-19
19cm/7 1/2"



18cm/7"

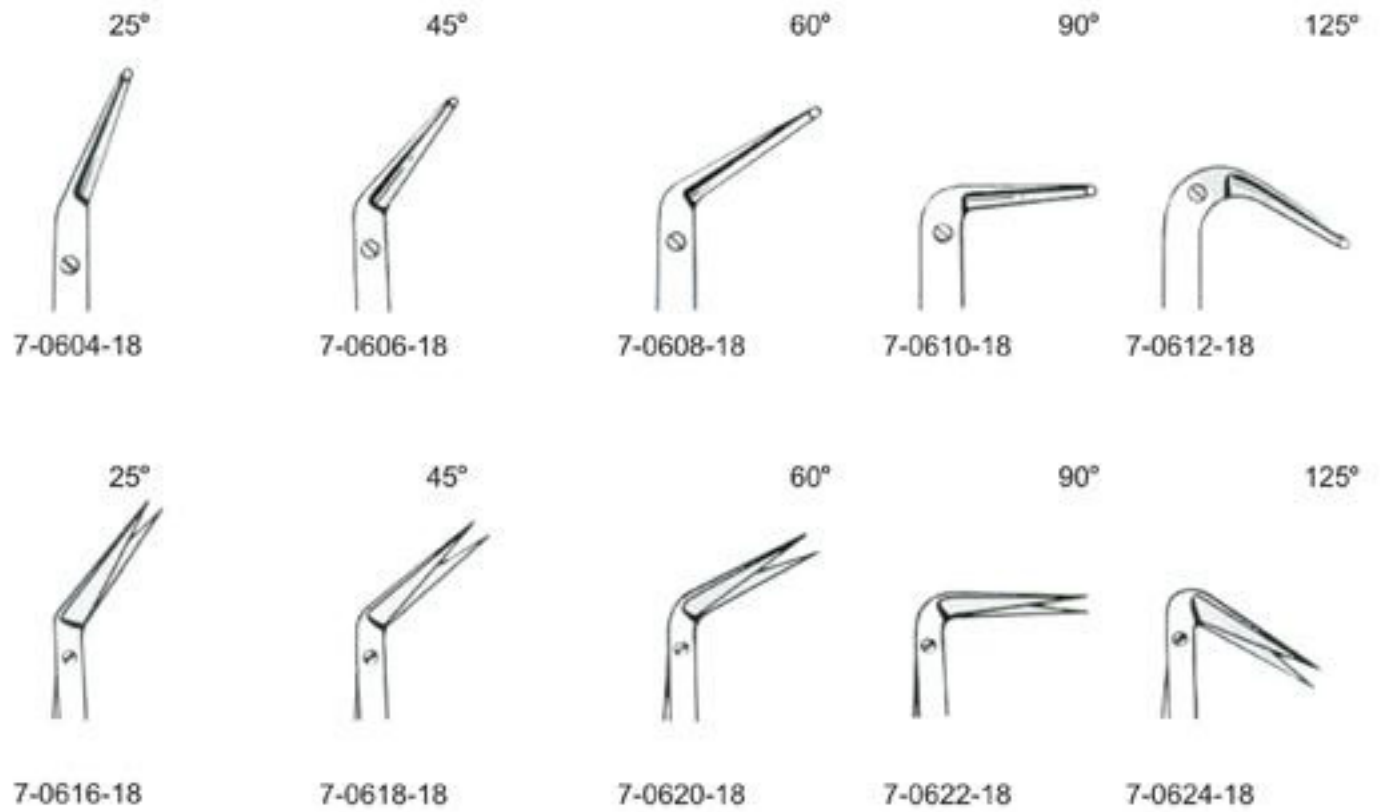

Nerve Dissecting Scissors



7-0628-15
15cm/6"

Tonsil Scissors



Bottcher
7-0632-18
18cm/7"



Prince
7-0636-17
17.5cm/7"

Arteriotomy Scissors



Adson-Fine
7-0640-17
17.5cm/7"

Straight



Tonnis
7-0645-18
18cm/7"

Curved



Tonnis
7-0650-18
18cm/7"



Adson
7-0652-17
17.5cm/7"



Adson
7-0656-17
17.5cm/7"

Tonsil Scissors



Good
7-0660-19
19 cm/7 1/2"

Lobectomy Scissors



Craford
7-0664-30
30 cm/12"



Finochietto
7-0668-27
27 cm/10 1/2"

Enterotomy Scissors



7-0673-21
21 cm/8 1/4"



7-0675-21
21 cm/8 1/4"



7-0677-21
21 cm/8 1/4"



Busch
7-0682-13 13 cm/5"
7-0682-16 16 cm/6 1/4"



Schumacher
7-0687-16
16 cm/6 1/4"



Mod. USA
7-0691-10
10.5cm/4 1/4"
7-0691-12
12.5cm



Braun-Stadler
7-0696-14
14 cm/5 1/2"



Braun-Stadler
7-0698-22
22 cm/8 1/2"



Parametrium



7-0702-23
23 cm/9"



7-0704-23
23 cm/9"



Heymann
7-0708-18
18 cm/7"



Heymann
7-0710-19
19.5 cm/7³/₄"



Knight
7-0714-18
18 cm/7"



Fomon
7-0718-13
13 cm/5"



Fomon
7-0722-13
13.5 cm/5¹/₄"



Fomon
7-0726-13
13.5 cm/5¹/₄"



Cottle
7-0730-16
16 cm/6¹/₄"



Halle
7-0734-19
19 cm/7¹/₄"

General Instruments

Dissecting, Trigeminal, Wire Cutting
and Gum Scissors

7



Strully
7-0738-22 22 cm/8¾" 7-0740-22



Dandy
7-0744-22
17 cm/6¾"



Trigeminal Scissors

Olivecrona
7-0749-15



Universal
7-0753-12
12 cm/4¾"



Goldman-Fox
Straight
7-0757-13
13 cm/5"



Goldman-Fox
Curved
7-0758-13
13 cm/5"



Fig. 1



Fig. 2



Fig. 3



Noyes
7-0767-12
12 cm/4¾"



Wecker
7-0770-01
11.5 cm/4½"



7-0770-02



7-0770-03



Barraquer
7-0774-05
5.5 cm/2¼"

Noyes
Fig.1 7-0763-01
Fig.2 7-0763-02
Fig.3 7-0763-03
12 cm/4¾"



7-0779-09
9 cm/3½"



7-0781-09



7-0783-09



7-0785-09



7-0788-09



7-0790-09



Straight

Vannas
7-0795-08
8 cm/3¼"



Curved

Vannas
7-0796-08
8 cm/3¼"



Angular

Vannas
7-0798-08
8 cm/3¼"



Vannas
7-0800-08
8 cm/3¼"



Straight

7-0805-08
8.5 cm/3¼"



Curved

7-0806-08
8.5 cm/3½"

Vannas Mod, Tubingen



Angular

7-0808-08
8.5 cm/3½"



Angular

7-0810-08
8.5 cm/3½"



7-0815-10
10 cm/4"



7-0816-10
10 cm/4"



Castroviejo
7-0818-10
10 cm/4"



Castroviejo
7-0820-10
10 cm/4"



Aebil
7-0822-10
10 cm/4"



Castroviejo
7-0826-10
10 cm/4"



Castroviejo
7-0828-10
10 cm/4"



Troutman-Barraquer
7-0832-10
10 cm/4"



Troutman-Barraquer
7-0834-10
10 cm/4"



Troutman
7-0838-10
10 cm/4"



Troutman
7-0840-10
10 cm/4"



Katzin-Barraquer
7-0844-10
10 cm/4"



Katzin-Barraquer
7-0846-10
10 cm/4"



Katzin
7-0850-10
10 cm/4"



Katzin
7-0852-10
10 cm/4"



Westcott
7-0856-11
11.5 cm/4½"



Westcott
7-0858-11
11.5 cm/4½"



Westcott
7-0860-11
11.5 cm/4½"



Castroviejo
7-0864-10
10 cm/4"



Castroviejo
7-0866-10
10 cm/4"



Castroviejo
7-0870-11
11.5 cm/4½"



Castroviejo
7-0872-11
11.5 cm/4½"



Troutmann-Castroviejo
7-0876-10
10.5 cm/4¼"



Troutmann-Castroviejo
7-0878-10
10.5 cm/4¼"



Straight
7-0883-14
7-0883-18

Curved
7-0884-14
7-0884-18

14.5 cm/5¾"
18.0 cm/7"



Straight

7-0889-12 12.0 cm/4¾"
7-0889-16 16.0 cm/6¼"
7-0889-18 18.5 cm/7¼"



Curved

7-0890-12 12.0 cm/4¾"
7-0890-16 16.0 cm/6¼"
7-0890-18 18.5 cm/7¼"



Vannas
Straight

7-0893-12 12.0 cm/4¾"
7-0893-16 16.0 cm/6¼"



Vannas
Curved

7-0894-12 12.0 cm/4¾"
7-0894-16 16.0 cm/6¼"



Yasargil

16.5cm/6½"
20.0cm/8"

20.0cm/8"

20.0cm/8"



Straight
7-0899-16
7-0899-20



Curved
7-0900-16
7-0900-20



Curved Downwards
7-0902-20

Dissecting Scissors



Straight
7-0907-20



Curved
7-0908-20



Yasargil

22.5cm/9"
24.5cm/9¾"

22.5cm/9"

22.5cm/9"



Straight
7-0913-22
7-0913-24



Curved
7-0914-22
7-0914-24



Curved Downwards
7-0916-22

Dissecting Scissors



Straight
7-0919-22



Curved
7-0920-22

7-0925-18



7-0931-19

7-0926-18



7-0932-19

7-0928-18



7-0934-19



7-0937-19



7-0938-19



Jacobson
18cm/7"



19cm/7 1/2"

Vein Scissors



Straight
7-0943-12
12cm/4¾"



Curved
7-0944-12
12cm/4¾"



Straight
7-0946-12
12cm/4¾"



Curved
7-0948-12
12cm/4¾"



Angled up
7-0950-12
12cm/4¾"



Straight
7-0955-13
13cm/5"



Saw Edge

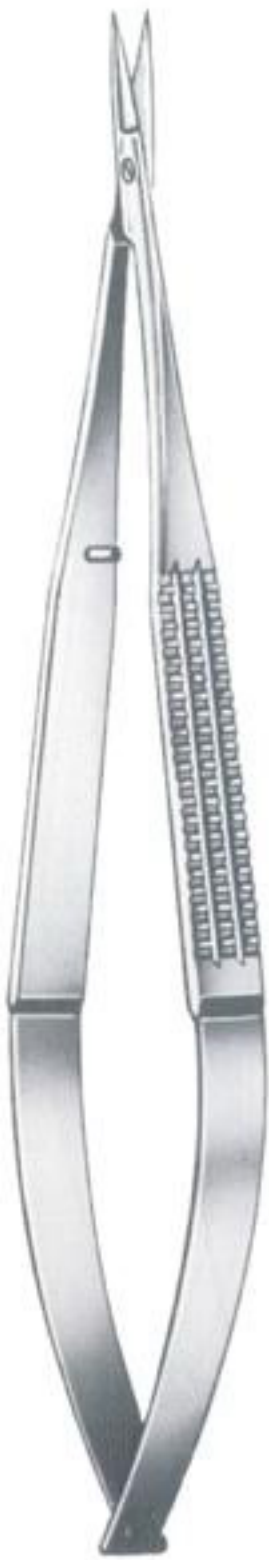

Straight
7-0959-16
16cm/6¼"



Curved
7-0960-16
16cm/6¼"



Straight
7-0962-16
16cm/6¼"



Curved
7-0964-16
16cm/6¼"



Millesi
Straight
7-0969-16
16cm/6¼"



Millesi
Curved
7-0970-16
16cm/6¼"



Straight
7-0975-18
18.5cm/7¼"



Curved
7-0976-18
18.5cm/7¼"



Angular
7-0978-18
18.5cm/7¼"



Saw Edge



Straight
7-0981-16
16cm/6¼"



Curved
7-0982-16
16cm/6¼"



Straight
7-0984-16
16cm/6¼"



Curved
7-0986-16
16cm/6¼"



Straight
7-0991-16
16cm/6¼"



Curved
7-0992-16
16cm/6¼"



Straight
7-0997-18
18.5cm/7¼"



Curved
7-0998-18
18.5cm/7¼"



Angular
7-1000-18
18.5cm/7¼"



Straight
7-1005-23
23cm/9"

Dissecting Scissors



Straight
7-1011-14
14.5cm/5¾"



Curved
7-1012-14
14.5cm/5¾"



Curved
7-1014-14
14.5cm/5¾"

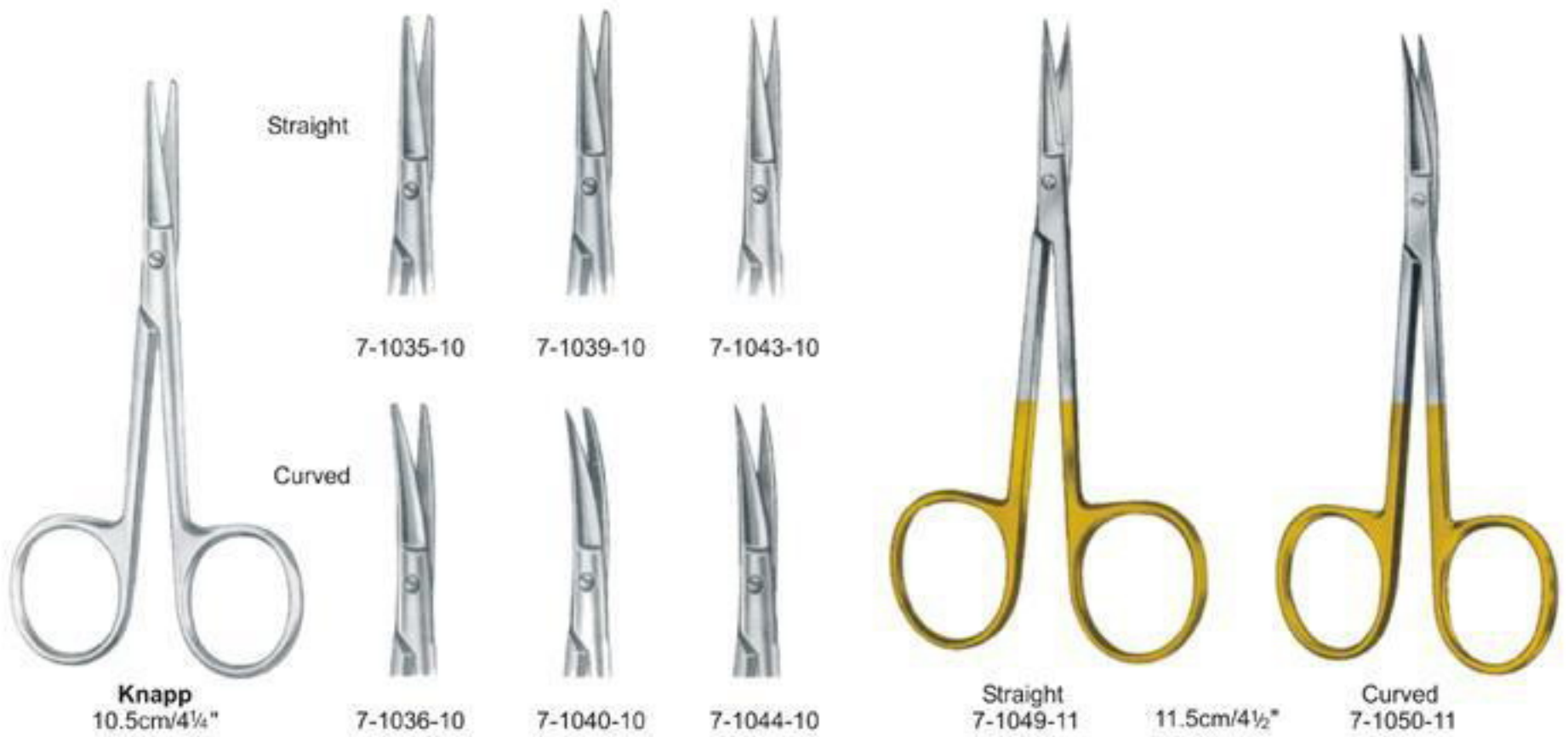



Standard

9.0 cm/3½"	7-1055-09	7-1056-09	7-1058-09	7-1060-09
10.5 cm/4¼"	7-1055-10	7-1056-10	7-1058-10	7-1060-10
11.5 cm/4½"	7-1055-11	7-1056-11	7-1058-11	7-1060-11



9.0cm/3½"		7-1067-09	7-1068-09
10.5cm/4¼"	7-1063-10	7-1067-10	7-1068-10
11.5cm/4½"	7-1063-11	7-1067-11	7-1068-11



Straight
Fine

9.5 cm/3¾"	7-1073-09
10.5 cm/4¼"	7-1073-10
11.5 cm/4½"	7-1073-11



Curved
Fine

7-1074-09
7-1074-10
7-1074-11



Straight

7-1077-10

Curved

10cm/4" 7-1078-10

Tenotomy Scissors



Stevens
10.5cm/4¼"
11.5cm/4½"



Pointed

Straight
7-1083-10
7-1083-11



Curved
7-1084-10
7-1084-11



Blunt

Straight
7-1087-10
7-1087-11



Curved
7-1088-10
7-1088-11



Straight
7-1091-08



Bonn
8cm/3¼" Curved
7-1092-08



Graefe
7-1096-10
10.5cm/4¼"



Wilmer
7-1100-10
10cm/4"



7-1105-11

11.5cm/4½"



7-1106-11

El cut



Straight
7-1109-11

11.5cm/4½"



Curved
7-1110-11



La Grange
7-1114-11
11.5cm/4½"



Chadwick
7-1118-11
11cm/4½"

Neurosurgical Scissors



Straight

7-1121-11
7-1121-13

11cm/4½"
13cm/5"



Curved

7-1122-11
7-1122-13



Potts-de Martel
7-1126-21
21cm/8¼"



Mills
7-1130-21
21cm/8¼"



Dura Scissors

Schmi eden-Taylor
7-1134-14 14.5cm/5¾"
7-1134-17 17.0cm/6¾"



7-1138-22

Strully
22cm/8¾"



7-1142-22



Dandy
7-1146-17
17cm/6¾"



Littauer
7-1151-14
14cm/5½"



Spencer
7-1153-09
9cm/3½"



Spencer
7-1155-10 10.5cm/4¼"
7-1155-12 12.0cm/4¾"



Spencer-Fine
7-1157-11 11.5cm/4½"
7-1157-16 16cm/6¼"



Shortbent
7-1160-09
9cm/3½"



Northbent
7-1164-12
12.5cm/5"



Spencer
7-1168-11
11.5cm/4½"



Littler
7-1172-11
11.5cm/4½"



Heath
7-1176-15
15cm/6"



7-1179-10
10cm/4"



Eiselsberg
7-1183-11
11.5cm/4½"



Schoemaker-Loth
7-1187-12
12.5cm/5"

Wire Cutting Scissors



Universal
7-1191-12
12cm/4¾"

Saw Edge



Universal

Black	7-1194-01
Blue	7-1194-02
Red	7-1194-03
Green	7-1194-04

14.5 cm/5¾"



Universal

Black	7-1196-01
Blue	7-1196-02
Red	7-1196-03
Green	7-1196-04

16 cm/6¼"



Universal

Black	7-1198-01
Blue	7-1198-02
Red	7-1198-03
Green	7-1198-04

18 cm/7"



Smith
7-1203-17
17.5 cm/7"



Saw edge

Harvey
7-1207-12
12.5 cm/5"



Saw edge

Schuknecht
7-1211-10
10 cm/4"



Nail Splinting Scissors

7-1215-13 13 cm/5"
7-1215-15 15 cm/6"



Lister
7-1220-09 9 cm/3½"
7-1220-13 13 cm/5"
7-1220-14 14 cm/5½"
7-1220-18 18 cm/7"
7-1220-20 20 cm/8"



Lister
7-1222-18
18 cm/7"



Lister
7-1224-18 18.5 cm/7¼"
7-1224-20 20 cm/8"



Lister-Excentric
7-1228-16 16 cm/6¼"
7-1228-19 19 cm/7½"



Esmarch
7-1232-20 20 cm/8"
7-1232-22 22 cm/8¾"



Bergmann
7-1236-23
23 cm/9"



Lorenz
7-1240-23
23 cm/9"



Saw edge

7-1246-17
17 cm/6¾"



Lange
7-1251-18
18 cm/7"



Bruns
7-1254-01 24 cm/9½" Saw edge
7-1254-02 24 cm/9½" Smooth
7-1254-03 24 cm/9½" Smooth

El cut



Smith (Mod. USA)
7-1259-16 16 cm/6¼"
7-1259-18 18 cm/7"
7-1259-20 20 cm/8"
7-1259-23 23 cm/9"



Knowles
7-1263-14
14 cm/5½"



Knowles
7-1266-14
14 cm/5½"



7-1270-13
13 cm/5"



7-1275-20
20 cm/8"



Seutin
7-1279-23
23 cm/9"



Bone Shear
7-1282-23
23 cm/9"



7-1285-22
22 cm/8¾"



Gluck
7-1289-22
22 cm/8¾"



Stille
7-1293-21
21 cm/8¼"



Stille
7-1297-24
24 cm/9½"



Stille
7-1301-23 23 cm/9"
7-1301-26 26 cm/10¼"
7-1301-37 37 cm/14½"



7-1303-23 23cm/9"
7-1303-26 26cm/10¼"
7-1303-37 37cm/14½"



Maurer collin
7-1305-24L 24 cm/9½"
7-1305-30L 30 cm/12"
7-1307-24R 24 cm/9½"
7-1307-30R 30 cm/12"



Bethune
7-1311-34
34 cm/13½"





Goldmann-Fox
7-1332-13
13 cm/5"

Saw edge



Goldmann-Fox
7-1333-13
13 cm/5"



Niro
7-1337-14
14 cm/5½"



**Goldmann-Fox
(Spezial)**
7-1343-13
13 cm/5"

Saw edge



7-1347-11
11.5 cm/4½"

Fine



Quinby
7-1350-12
12 cm/4¾"



Quinby
7-1351-12
12 cm/4¾"



Saw edge

Dean
7-1355-17
17 cm/6³/₄"



Dean
7-1357-17
17 cm/6³/₄"



Saw edge

Locklin
7-1361-16
16.5 cm/6¹/₂"



Locklin
7-1363-16
16.5 cm/6¹/₂"



Saw edge

Sullivan
7-1366-14
14.5 cm/5³/₈"



Sullivan
7-1367-14
14.5 cm/5³/₈"



Neumann
7-1371-12
12 cm/5"



Nail scissors



General Instruments

Dressing Forceps

8

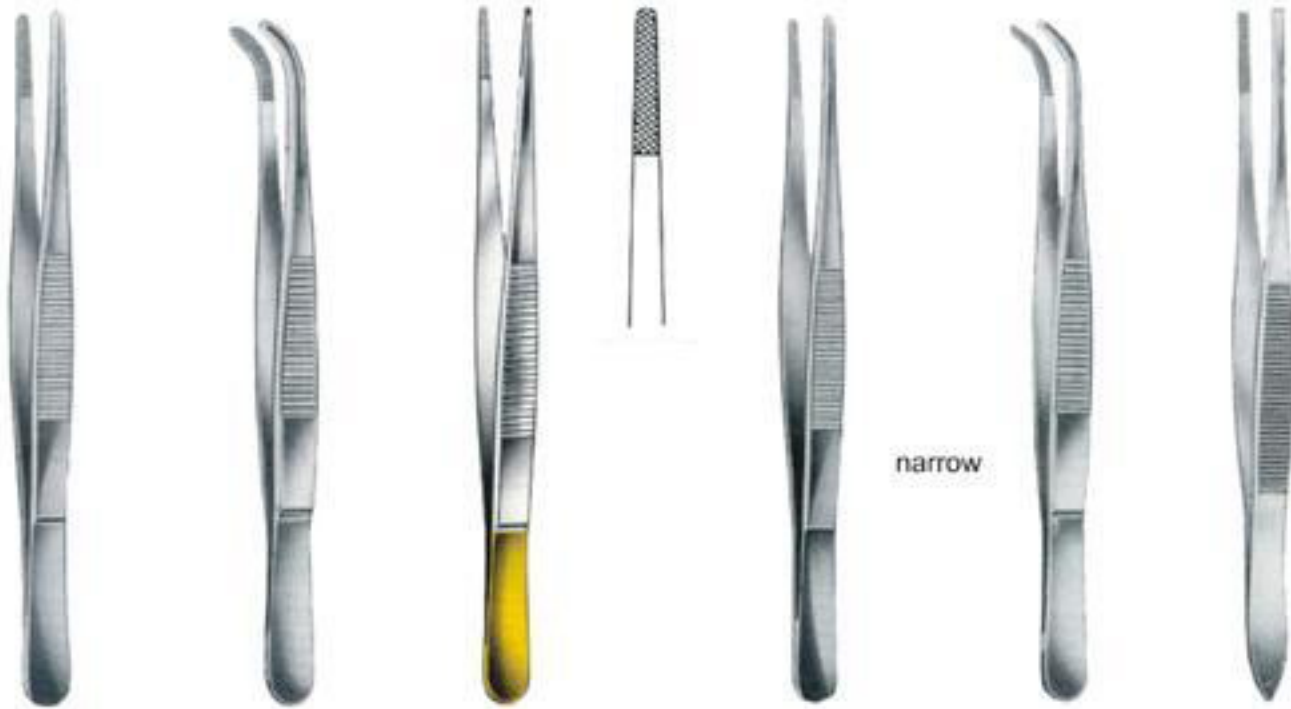

cm	in	Standard	Standard	Standard	narrow		Stille
10.5	4 ¹ / ₄ "	8-0005-10					
11.5	4 ¹ / ₂ "	8-0005-11	8-0006-11		8-0016-11	8-0017-11	
13.0	5"	8-0005-13	8-0006-13		8-0016-13	8-0017-13	8-0021-13
14.5	5 ³ / ₄ "	8-0005-14	8-0006-14	8-0011-14	8-0016-14	8-0017-14	
15.0	6"	8-0005-15					8-0021-15
16.0	6 ¹ / ₄ "	8-0005-16	8-0006-16	8-0011-16	8-0016-16	8-0017-16	
18.0	7"	8-0005-18	8-0006-18	8-0011-18	8-0016-18	8-0017-18	8-0021-18
20.0	8"	8-0005-20		8-0011-20	8-0016-20		8-0021-20
25.0	10"	8-0005-25		8-0011-25	8-0016-25		
30.0	12"	8-0005-30			8-0016-30		

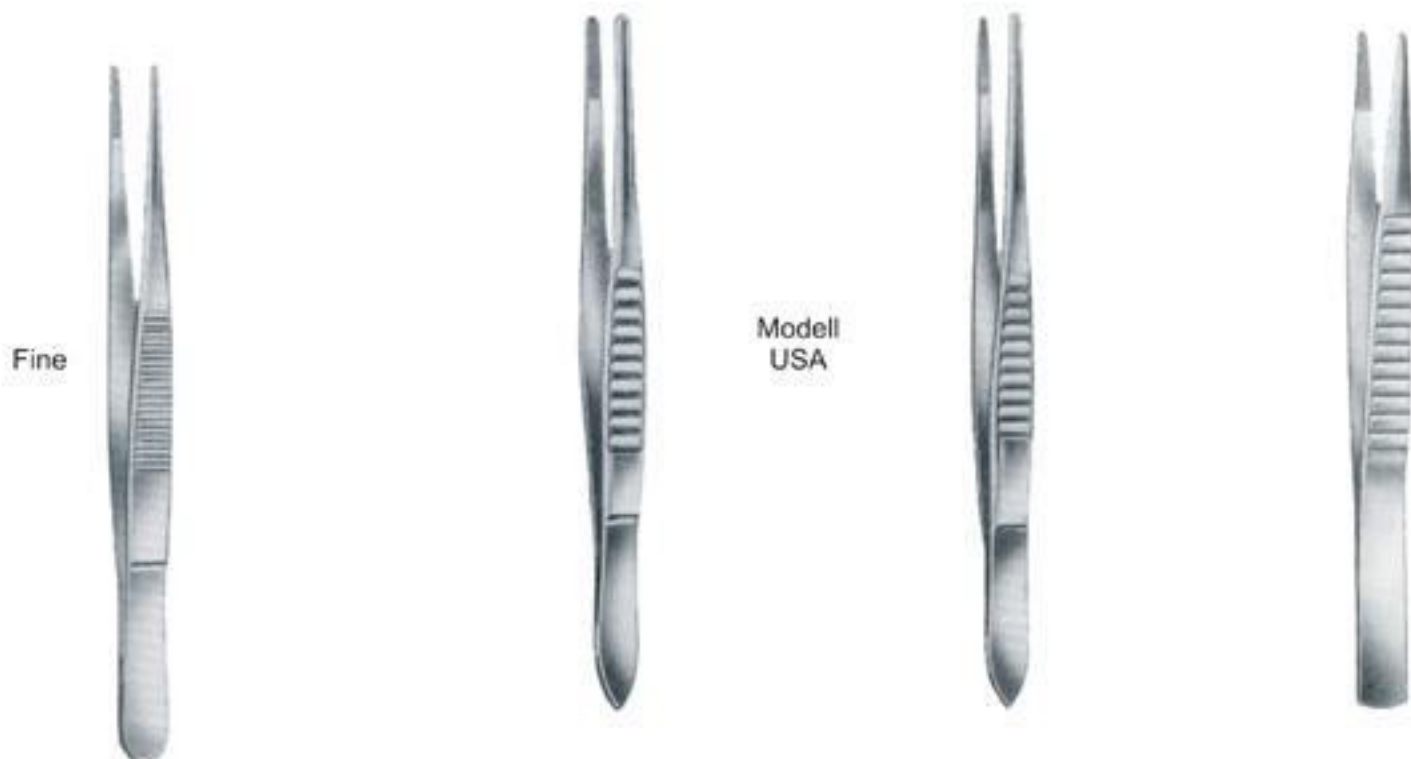

cm	in	Standard	Narrow	Engl. Modell
11.5	4 ¹ / ₂ "	8-0025-11		
12.0	4 ³ / ₄ "		8-0029-12	8-0033-12
13.0	5"	8-0025-13	8-0029-13	8-0033-13
14.5	5 ³ / ₄ "	8-0025-14	8-0029-14	8-0033-14
15.0	6"	8-0025-15	8-0029-15	8-0033-15
16.0	6 ¹ / ₄ "	8-0025-16	8-0029-16	
18.0	7"	8-0025-18	8-0029-18	
20.0	8"	8-0025-20		
21.0	8 ¹ / ₄ "		8-0029-21	
25.0	10"		8-0029-25	
30.0	12"		8-0029-30	

General Instruments

Dressing Forceps

8

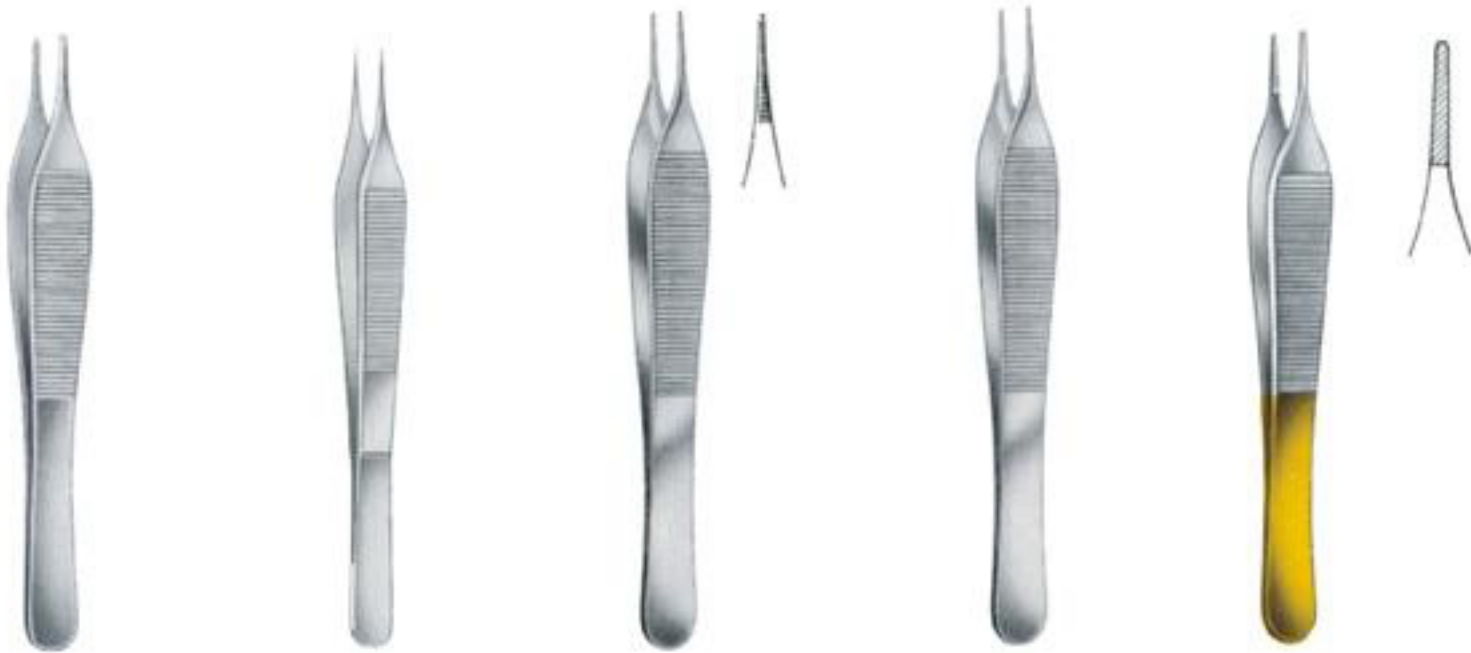

cm	in	Ewald	Jacobson-Adson	Micro-Adson	Adson-Standard	Adson
12.0	4¾"	8-0041-12	8-0045-12	8-0049-12	8-0053-12	8-0057-12
15.5	6"	8-0041-15	8-0045-15	8-0049-15	8-0063-15	8-0057-15

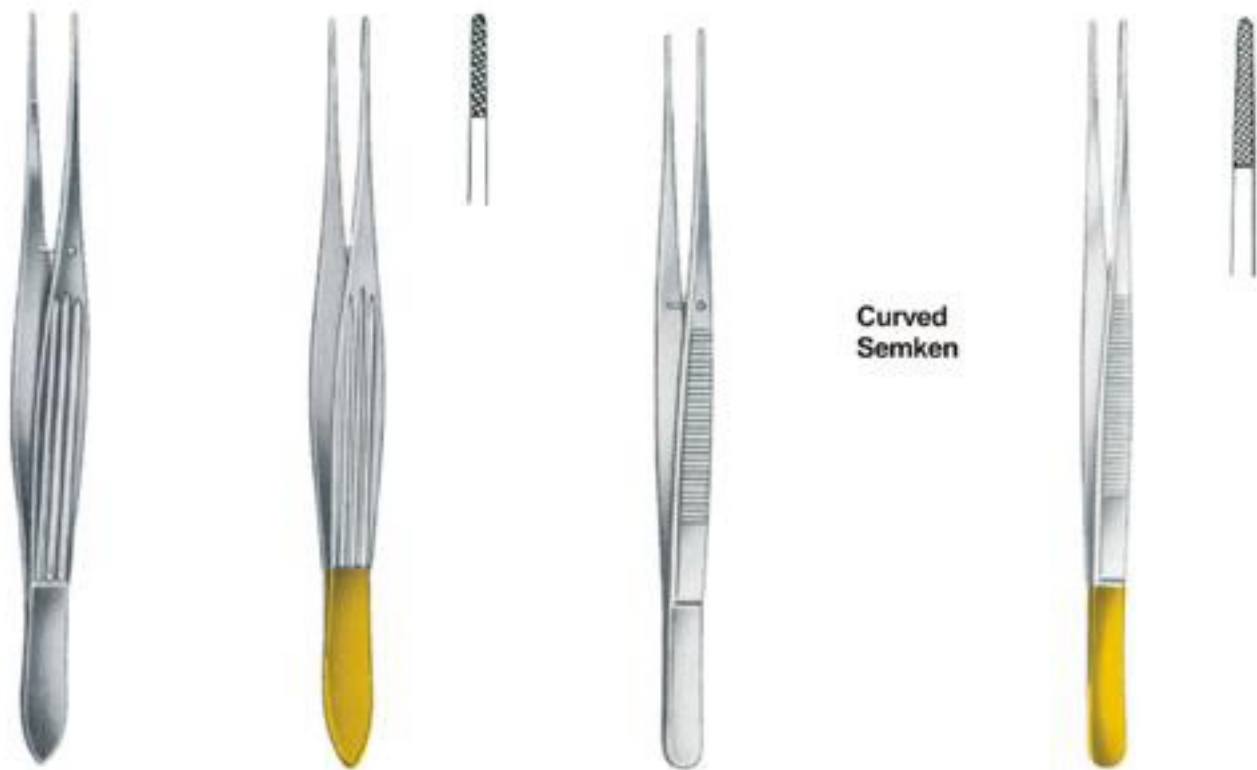

cm	in	McIndoe	McIndoe	Semken	Semken	Semken
12.0	4¾"			8-0067-12	8-0068-12	8-0073-12
15.0	6"	8-0061-15	8-0063-15	8-0067-15	8-0068-15	8-0073-15

General Instruments

Dressing Forceps

8



8-0077-17



8-0078-17



Taylor
8-0083-17
17.5cm/7"



8-0084-17



With Dissector

8-0089-17

Smooth Jaw



8-0098-20



Bonney

8-0103-18



Brophy

8-0107-18



Brophy

8-0108-18

cm	in	Waugh
15.0	6"	8-0093-15
18.0	7"	8-0093-18
20.0	8"	8-0093-20

8-0097-18

8-0097-20

General Instruments

Micro Forceps

8

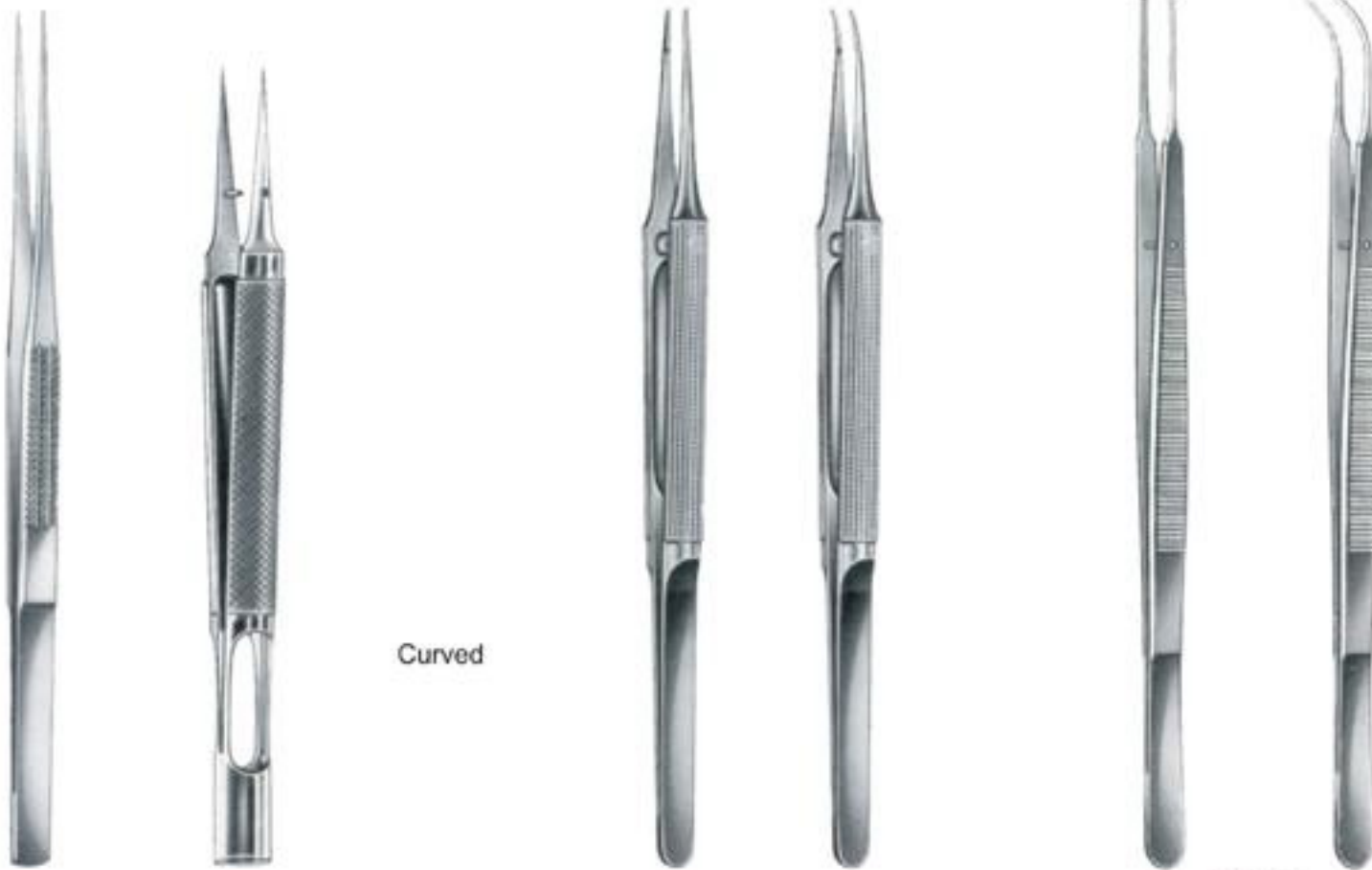

Curved

Gerald

cm	in						
12.0	4 ³ / ₄ "			8-0123-12	8-0124-12		
13.0	5"	8-0117-13	8-0118-13				
15.0	6"	8-0113-15		8-0123-15	8-0124-15		
17.5	7"					8-0129-17	8-0130-17
18.0	7"	8-0113-18		8-0123-18	8-0124-18		

Micro Tubal Forceps



Austin
8-0135-14
14cm/5¹/₂"

Austin
8-0137-18
18cm/7"

Neubuser
8-0141-20
20cm/8"

General Instruments

Dressing Forceps

8



cm	in	Cushing	Cushing	Cushing	Cushing	Cushing-Taylor	Grunwald
18.0	7	8-0145-18	8-0146-18	8-0149-18	8-0150-18	8-0155-18	8-0159-18



cm	in	Wangensteen		Potts-Smith			
15.0	6"	8-0163-15					
18.0	7"		8-0165-18	8-0169-18	8-0170-18	8-0175-15	
20.0	8"			8-0169-21		8-0175-18	
21.0	8 1/4"			8-0169-25	8-0170-21	8-0175-20	
23.0	9"	8-0163-23	8-0165-23			8-0175-23	
25.0	10"	8-0163-25			8-0170-25	8-0175-25	

General Instruments

Tissue Forceps

8



cm	in	Standard 1:2	Oehler 1:2	Standard 2:3	Standard 3:4	Standard 4:5	Standard 1:2
10.5	4¼"	8-0179-10					
11.5	4½"	8-0179-11					
13.0	5"	8-0179-13		8-0187-13	8-0191-13	8-0195-13	8-0199-13
14.5	5½"	8-0179-14	8-0183-14	8-0187-14	8-0191-14	8-0195-14	8-0199-14
15.0	6"	8-0179-15					
16.0	6¼"	8-0179-16	8-0183-16	8-0187-16	8-0191-16	8-0195-16	8-0199-16
18.0	7"	8-0179-18	8-0183-18	8-0187-18			8-0199-18
20.0	8"	8-0179-20	8-0183-20	8-0187-20			8-0199-20
25.0	10"	8-0179-25	8-0183-25	8-0187-25			8-0199-25
30.0	12"	8-0179-30	8-0183-30	8-0187-30			

General Instruments

Tissue Forceps

8



Modell
USA



Modell
USA



Modell
USA



narrow

Standard

cm	in	1:2	2:3	3:4	1:2
12.0	4 ³ / ₄ "	8-0203-12	8-0207-12		
13.0	5"	8-0203-13	8-0207-13		8-0215-13
14.5	5 ³ / ₄ "	8-0203-14	8-0207-14	8-0211-14	8-0215-14
15.5	6"	8-0203-15			8-0215-15
18.5	7 ¹ / ₄ "	8-0203-18	8-0207-18		
21.0	8 ¹ / ₄ "	8-0203-21	8-0207-21		
25.0	10"	8-0203-25	8-0207-25		
31.0	12 ¹ / ₄ "	8-0203-31	8-0207-31		



cm	in	Lerche	Stone	Treves
13.0	5"			8-0227-13
15.0	6"	8-0219-15	8-0223-15	8-0227-15

General Instruments

Tissue Forceps

8



cm	in	Micro-Adson			Ewald	Standard-Adson
12.0	4¾"	8-0231-12	8-0233-12	8-0235-12	8-0239-12	8-0243-12
15.5	6"	8-0231-15	8-0233-15	8-0235-15		8-0243-15



cm	in	Adson			Adson-Brown		
12.0	4¾"	8-0247-12	8-0249-12	8-0251-12	8-0255-12	8-0257-12	8-0259-12
15.0	6"	8-0247-15	8-0249-15				



Gillies
8-0263-15 15 cm/6"



Gillies
8-0265-15 15 cm/6"



Brown
8-0269-15 15 cm/6"
8-0269-20 20 cm/8"
8-0269-25 25 cm/10"



Semken
8-0273-12 12 cm/4¾" 8-0275-12
8-0273-15 15 cm/6" 8-0275-15



Adlerkreutz
8-0279-15 15 cm/6"
8-0279-20 20 cm/8"
8-0279-25 25 cm/10"



Adlerkreutz
8-0281-15 15 cm/6"
8-0281-20 20 cm/8"
8-0281-25 25 cm/10"



Taylor
8-0285-17 17.5 cm/7"



Taylor
8-0286-17 17.5 cm/7"



Taylor
8-0289-17 17.5 cm/7"



Taylor
8-0291-17 17.5 cm/7"

General Instruments

Tissue Forceps

8



cm	in.	Waugh	Brophy	Brophy	Gerald	Gerald
15	6"	8-0295-15				
18	7"	8-0295-18			8-0305-18	8-0306-18
20	8"	8-0295-20	8-0299-20	8-0301-20		

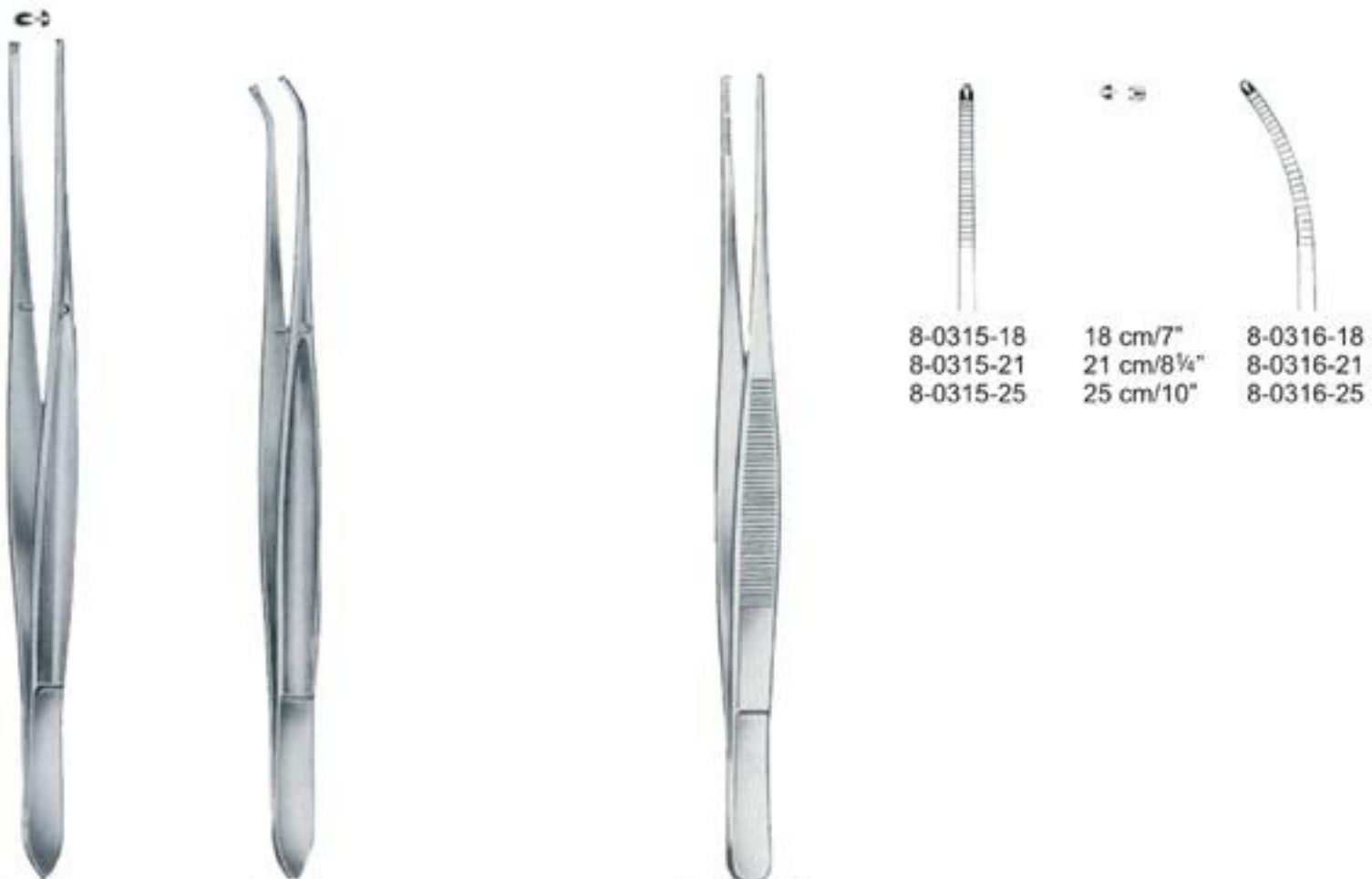

Cushing
8-0309-18
17.5 cm/7"

Cushing
8-0310-18
17.5 cm/7"

Potts-Smith

8-0315-18
8-0315-21
8-0315-25

18 cm/7"
21 cm/8 1/4"
25 cm/10"

8-0316-18
8-0316-21
8-0316-25



Duval
8-0319-14
14.5 cm/5 1/2"



Collin-Duval
8-0323-20
20 cm/8"



Durante
8-0327-14 14.5 cm/5 3/4"
8-0327-16 16.0 cm/6 1/4"
8-0327-20 20.0 cm/8"



Russ. Modell
8-0331-15 15 cm/6"
8-0331-20 20 cm/8"
8-0331-25 25 cm/10"



Mayo
8-0335-23
23 cm/9"

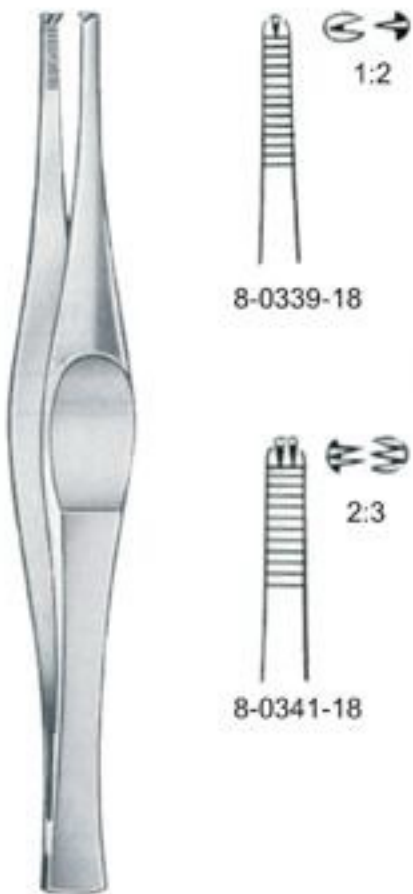

Ferris-Smith
18 cm/7"



Ramsay
8-0345-17
17.5cm/7"



Lane
8-0353-12 12 cm/5" 8-0355-12
8-0353-15 15cm/6" 8-0355-15
8-0353-18 18cm/7" 8-0355-18
8-0353-20 20cm/8" 8-0355-20

Grasping Forceps

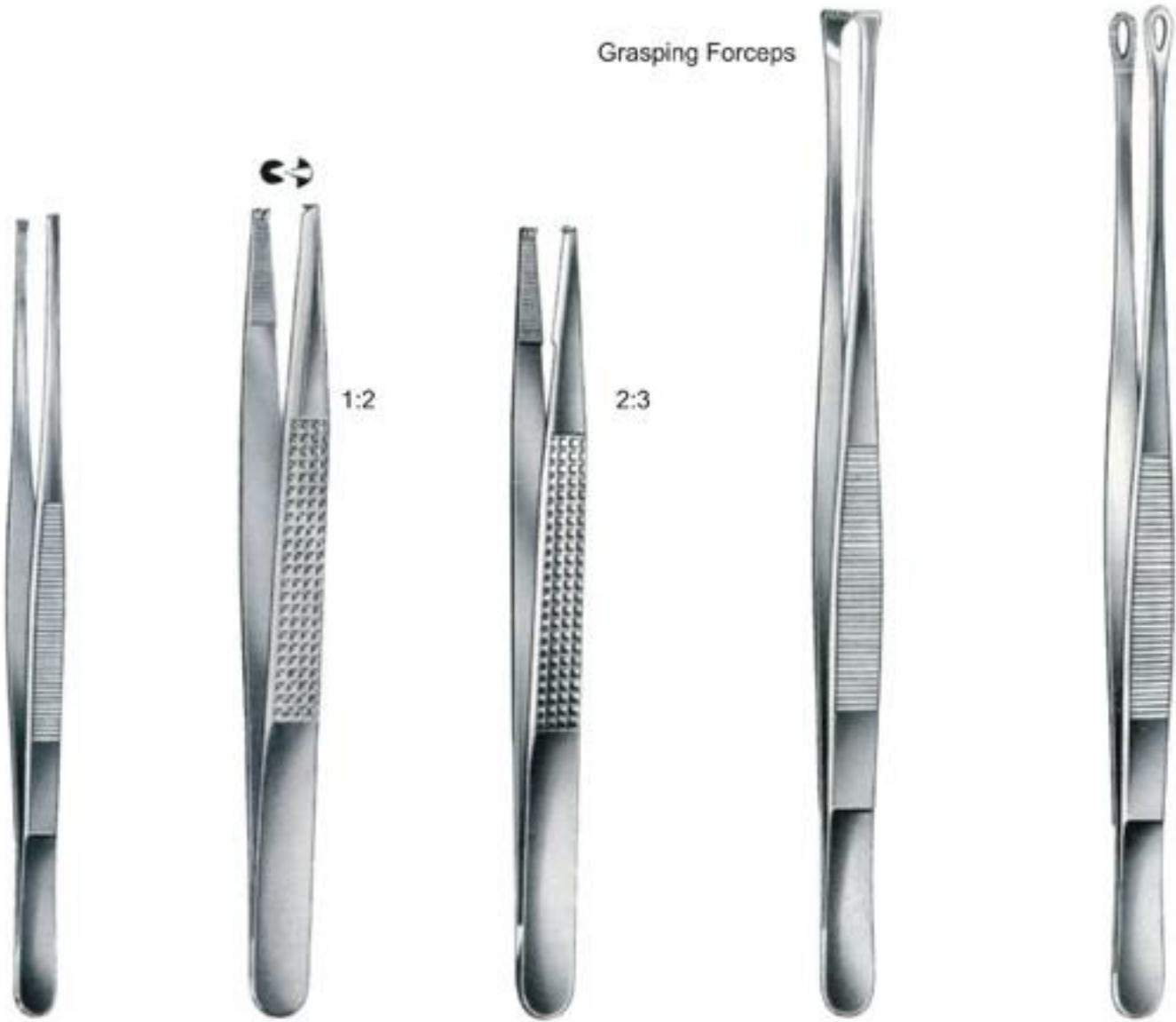

cm	in	Stille-Barraya	Bonney	Bonney	Nelson	Singley-Tuttle
15.0	6"				8-0369-15	
18.0	7"	8-0359-18	8-0363-18	8-0365-18	8-0369-18	8-0371-18
20.0	8"	8-0359-20			8-0369-23	
23.0	9"					8-0371-23
25.0	10"	8-0359-25				

Watchmaker's Forceps



No. 3 8-0374-03 11.5cm/4½"	No. 4 8-0375-04 11.5cm/4½"	No. 5 8-0376-05 11.5cm/4½"	No. 7 8-0377-07 11.5cm/4½"
----------------------------------	----------------------------------	----------------------------------	----------------------------------

General Instruments

Fine and Splinter Forceps

8



cm	in						
10.5	4 1/4"	8-0379-10	8-0380-10	Graefe 8-0382-10	8-0385-10	8-0386-10	8-0388-10

Splinter Forceps

With pin



Smooth

cm	in				
9.0	3 1/2"	8-0391-09	8-0392-09	8-0395-09	8-0396-09
10.5	4 1/4"	8-0391-10	8-0392-10	8-0395-10	8-0396-10
11.5	4 1/2"	8-0391-11	8-0392-11	8-0395-11	8-0396-11
12.5	5"	8-0391-12	8-0392-12	8-0395-12	8-0396-12



Feilchenfeld

8-0399-07 7.5cm/3"
8-0399-09 9.0cm/3½"
8-0399-11 11.5cm/4½"



Hunter

8-0403-10 10.5cm/4¼" 8-0404-10



Walter-Carmalt

8-0407-10 10.5cm/4¼" 8-0408-10



Peet

8-0412-11
11.5cm/4½"



8-0415-13 with out ratchet
8-0417-13 with ratchet



Stieglitz



8-0420-13
13cm/5¼"
45°



8-0422-13
13cm/5¼"
90°



Ralk
8-0425-15
15cm/6"



Ralk
8-0426-15
15cm/6"

Ligature Forceps



Ochsner
8-0429-14
14.5cm/5 3/4"



Adson
8-0433-12
12cm/4 3/4"



Adson
8-0435-12
12cm/4 3/4"

Cilia Forceps



Beaupre
8-0438-12
12cm/4 3/4"



Henry
8-0441-12
12cm/4 3/4"



Gradle
8-0445-09
9.5cm/3 3/4"



Barraquer
8-0448-10
10.5cm/4 1/4"



Bennett
8-0451-07
7cm/2 3/4"



cm	in	Beer	Douglas	Ziegler
9.0	3 1/2"	8-0455-09	8-0459-09	8-0463-09



Kuehne
8-0469-10
10.5cm/4 1/4"

Kuehne
8-0470-10
10.5cm/4 1/4"

8-0473-10
10.5cm/4 1/4"

General Instruments

Atrauma Tissue, Ear Dressing and Nasal Dressing Forceps

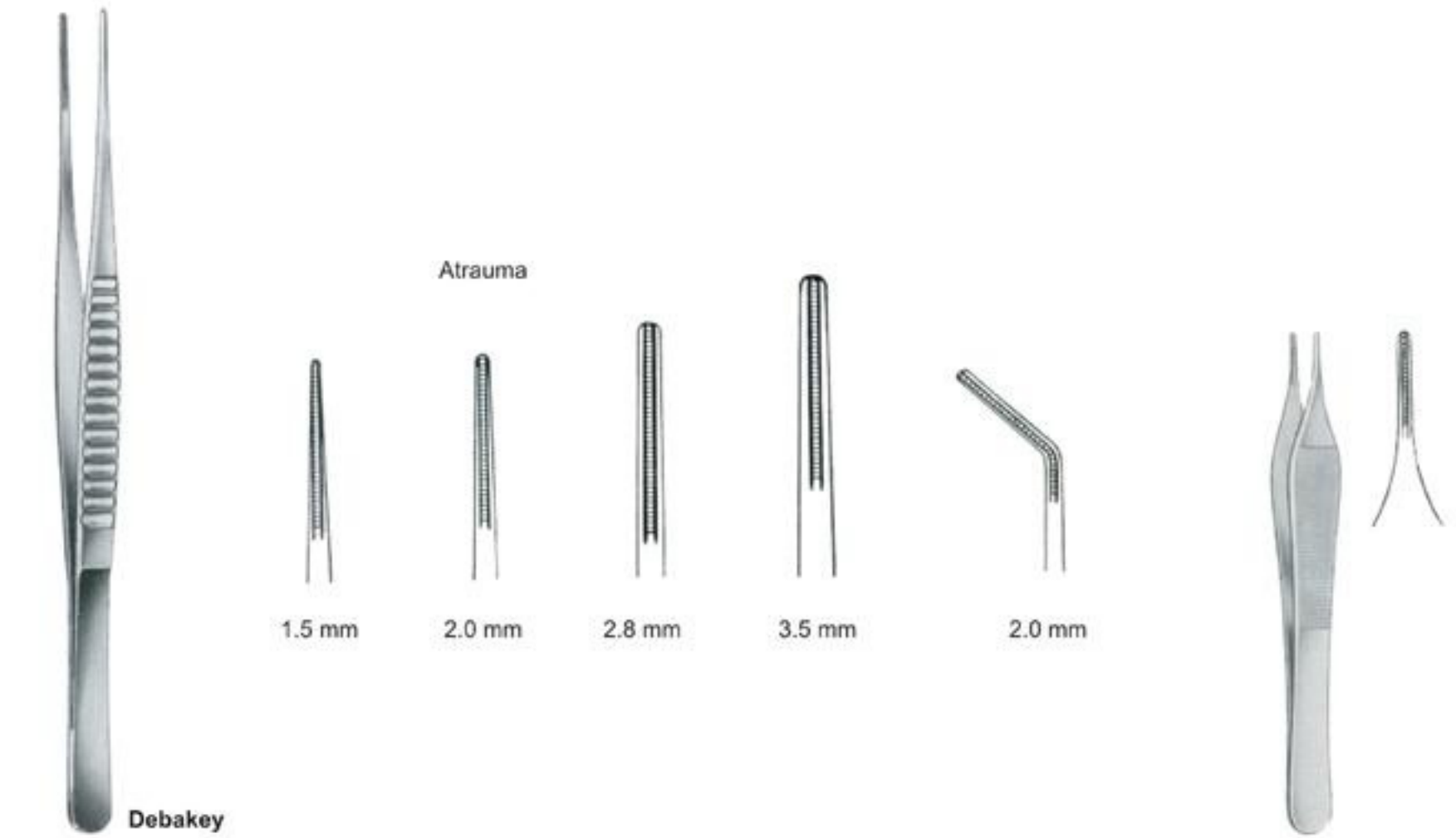

cm	in	1.5 mm	2.0 mm	2.8 mm	3.5 mm	2.0 mm
16.0	6¼"	8-0477-16	8-0479-16	8-0481-16	8-0483-16	8-0484-16
20.0	8"	8-0477-20	8-0479-20	8-0481-20	8-0483-20	8-0484-20
24.0	9½"	8-0477-24	8-0479-24	8-0481-24	8-0483-24	8-0484-24
30.0	12"	8-0477-30	8-0479-30	8-0481-30	8-0483-30	8-0484-30

Adson

8-0489-12	12cm/4¾"
8-0489-15	15cm/6"



cm	in	Troeltsch (Wilde)	Troeltsch	Lucae	Lucae	Jansen (Gruenwald)	Jansen
11.5	4½"	8-0494-11					
12.0	4¾"	8-0494-12	8-0496-12	8-0500-14	8-0504-14		
14.0	5½"						
15.0	6"	8-0494-15					
16.0	6¼"					8-0508-16	8-0512-16
18.0	7"	8-0494-18				8-0508-18	8-0512-18
20.0	8"					8-0508-20	8-0512-20



Yasargil
22cm/8½"



Jaw spoon, Shaped
3 mm 8-0516-03
5 mm 8-0516-05



Jaw falt, Serrated
3 mm 8-0518-03
5 mm 8-0518-05



Curette Jaw, Toothed
3 mm 8-0520-03
5 mm 8-0520-05



1 x 0.5 mm \varnothing



1 x 0.5 mm \varnothing
8-0525-16



2 x 1 mm \varnothing



2 x 1 mm \varnothing

15cm/6"	8-0525-16	8-0527-16	8-0529-18	8-0531-18
18cm/7"				
22cm/8¾"	8-0525-22	8-0527-22	8-0529-22	8-0531-22



Yasargil

22cm/8¾"
24cm/9½"

⊙
∅ 3 mm
8-0536-22
8-0536-24

⊙
∅ 5 mm
8-0538-22
8-0538-24

⊙
∅ 7 mm
8-0540-24

22cm/8¾"

⊙
∅ 3 mm
8-0544-22

⊙
∅ 3 mm
8-0546-22

⊙
∅ 5 mm
8-0548-22

⊙
∅ 5 mm
8-0550-22
22cm/8¾"



Yasargil

16cm/6 1/4"
18cm/7"
20cm/8"
22cm/8 3/4"
24cm/9 1/2"



0.6 mm
8-0554-16
8-0554-18
8-0554-20
8-0554-22
8-0554-24



0.9 mm
8-0556-16
8-0556-18
8-0556-20
8-0556-22
8-0556-24



8-0558-18
18cm/7"



Dieffenbach
9-0005-03
3.5cm/1½"
9-0005-05
5cm/2"



Dieffenbach
9-0006-03
3.5cm/1½"
9-0006-05
5cm/2"

Straight

- 9-0013-01 38mm/1½"
- 9-0013-02 51mm/2"
- 9-0013-03 57mm/2¼"
- 9-0013-04 63mm/2½"
- 9-0013-05 70mm/2¾"
- 9-0013-06 75mm/3"
- 9-0013-07 90mm/3½"



Johns-Hopkins

Curved

- 9-0014-01 38mm/1½"
- 9-0014-02 51mm/2"
- 9-0014-03 57mm/2¼"
- 9-0014-04 63mm/2½"
- 9-0014-05 70mm/2¾"
- 9-0014-06 75mm/3"
- 9-0014-07 90mm/3½"



Dieffenbach
9-0009-06
6cm/2½"



Dieffenbach
9-0010-06
6cm/2½"



Carrel
9-0019-10
10cm/4"



Terrier
9-0023-10
10cm/4"



Terrier
9-0027-12
12cm/4¾"



Chaput
9-0031-13
13cm/5"

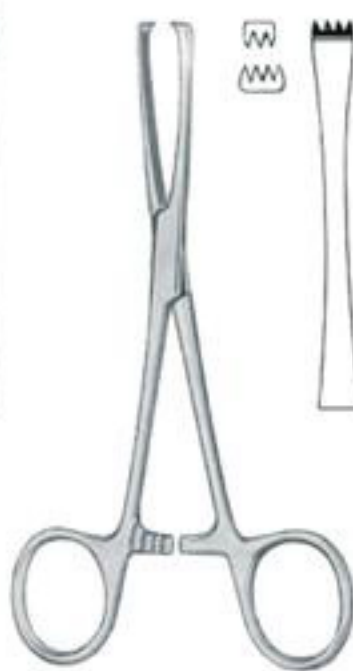

Tuffier
9-0035-13
13cm/5"



Pratt
9-0039-15
15cm/6"

Haemorrhoidal Clamps



Ombredanne
9-0043-13
13 cm/5¼"



Pennington
9-0047-15 15 cm/6"
9-0047-20 20 cm/8"

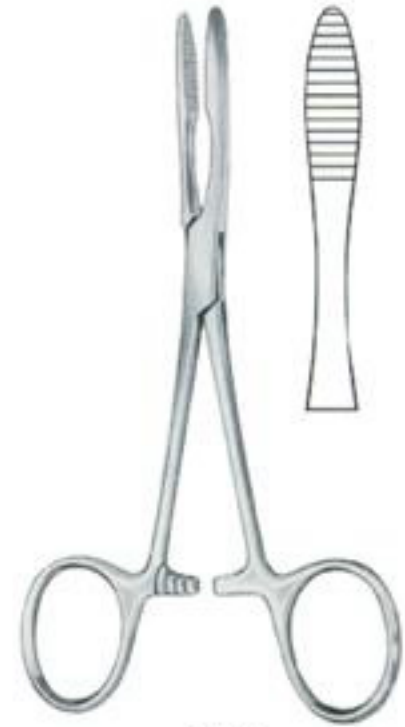

Pean
9-0051-14 14 cm/5½"
9-0051-16 16 cm/6¼"



Collin
9-0055-15
15.5 cm/6"



Collin
9-0059-14
14 cm/5½"



Collin
21-0396-16
16.5 cm/6½"



Hartmann
10 cm/4"



9-0067-10



9-0073-10



9-0068-10



9-0074-10



Halstead-Mosquito
12 cm/4¾"
14 cm/5½"



9-0079-12
9-0079-14



9-0083-12
9-0083-14



9-0080-12
9-0080-14



9-0084-12
9-0084-14



Micro-Mosquito
10 cm/4"
12 cm/4¾"



9-0089-10
9-0089-12



9-0093-10
9-0093-12

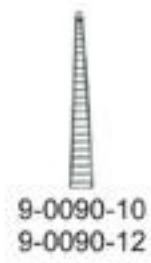

9-0090-10
9-0090-12

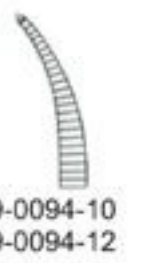

9-0094-10
9-0094-12



Jacobson-Halstead
13 cm/5"

Very fine



9-0098-13



9-0100-13

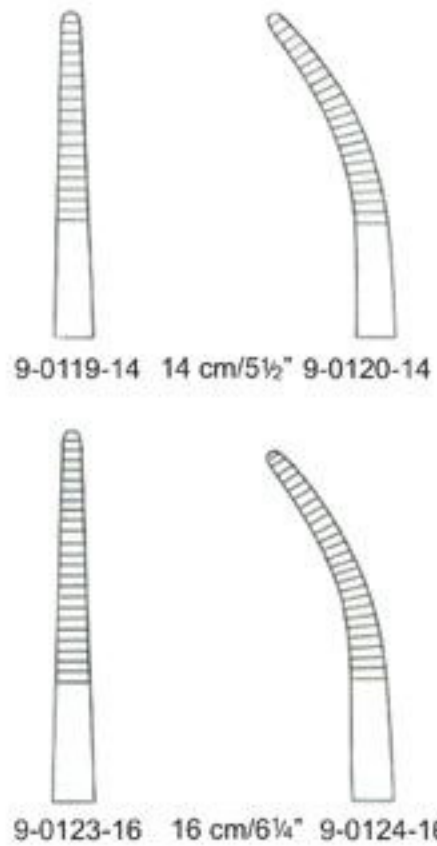



Crile
14 cm/5½"

Crile-Rankin
16 cm/6¼"

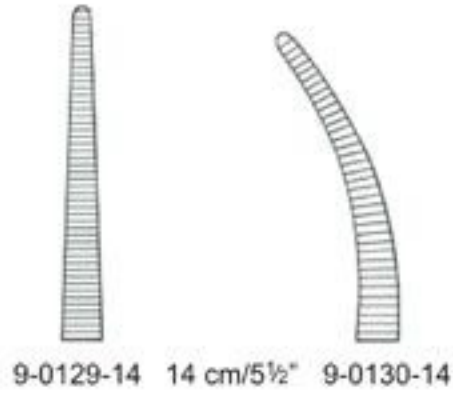

9-0129-14 14 cm/5½" 9-0130-14

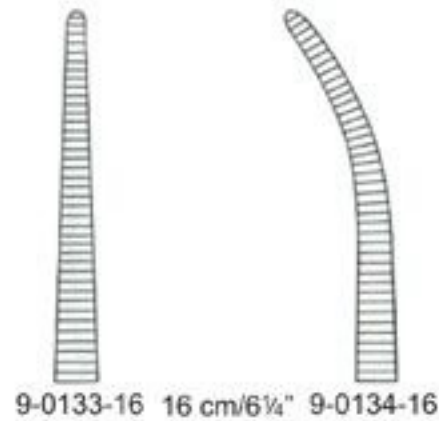

9-0133-16 16 cm/6¼" 9-0134-16



Baby-Crile
14 cm/5½"

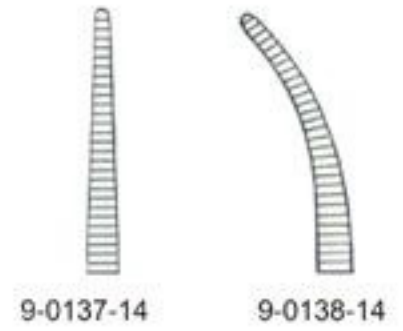

9-0137-14 9-0138-14



Crile
14 cm/5½"

Crile-Rankin
16 cm/6¼"

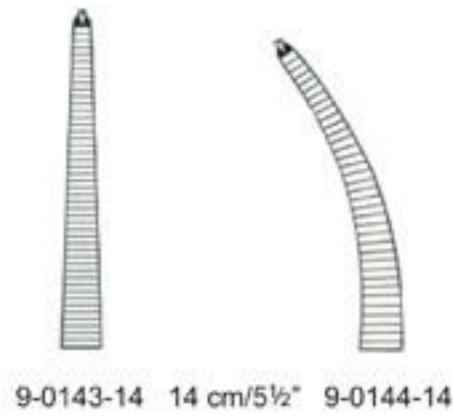

9-0143-14 14 cm/5½" 9-0144-14

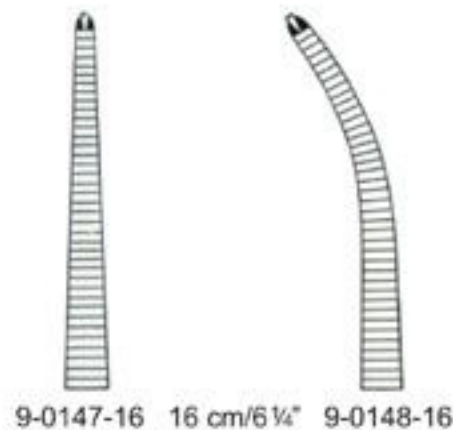

9-0147-16 16 cm/6¼" 9-0148-16



Baby-Crile
14 cm/5½"

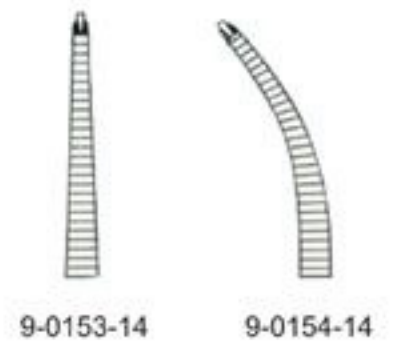

9-0153-14 9-0154-14



Coller-Crile

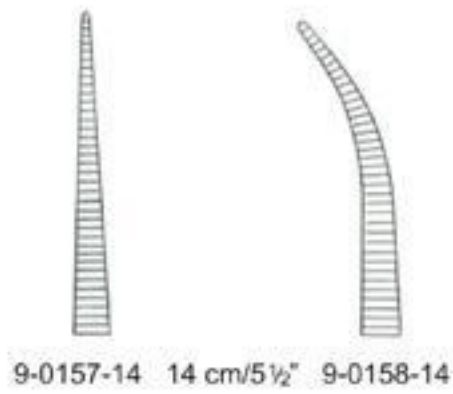

9-0157-14 14 cm/5½" 9-0158-14



9-0161-16 16 cm/6¼" 9-0162-16



Coller-Crile
 9-0166-16
 16 cm/6¼"



Leriche
 15 cm/6"

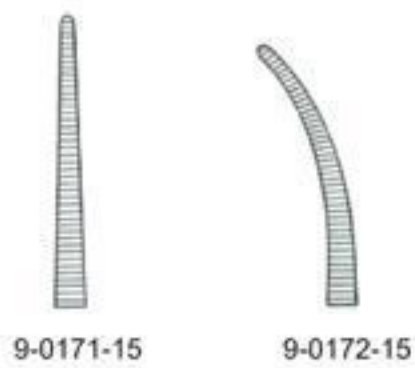

9-0171-15 9-0172-15



9-0175-15 9-0176-15



Providence
 14 cm/5½"



9-0179-14



9-0180-14

General Instruments

Hemostatic Forceps

9

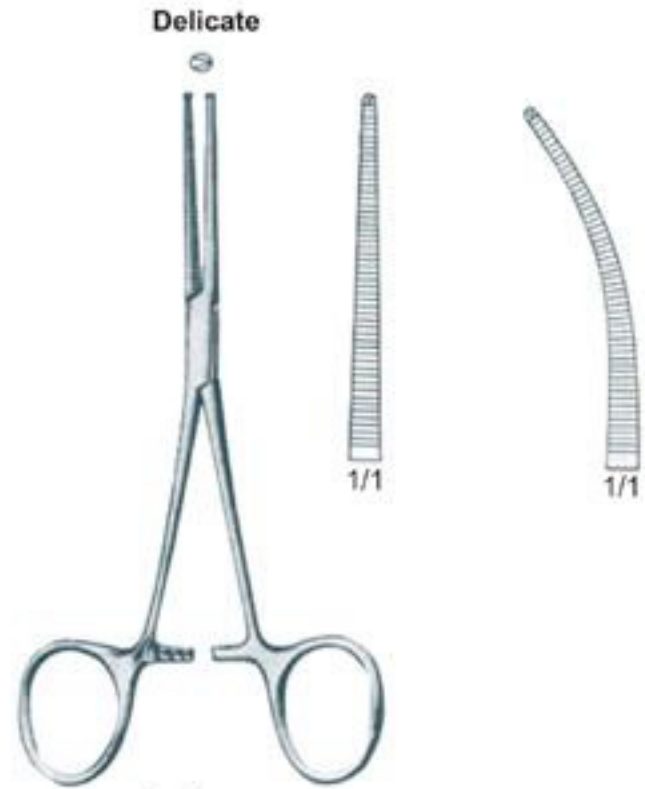

Fine

Pean		cm	in	Kocher	
9-0183-13	9-0184-13	13.0	5"	9-0187-13	9-0188-13
9-0183-14	9-0184-14	14.0	5 1/2"	9-0187-14	9-0188-14
9-0183-16	9-0184-16	16.0	6 1/4"	9-0187-16	9-0188-16

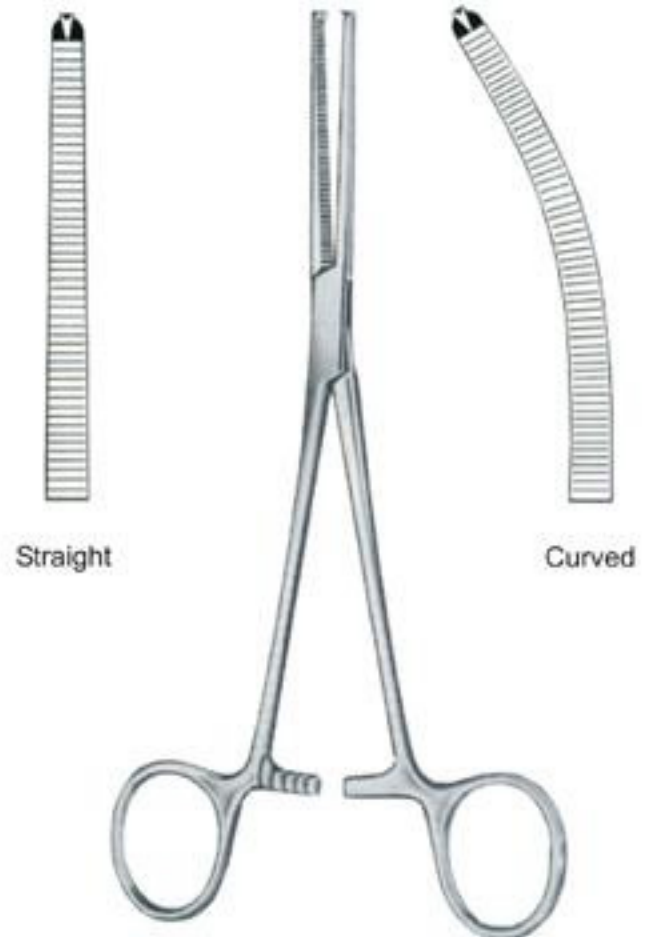
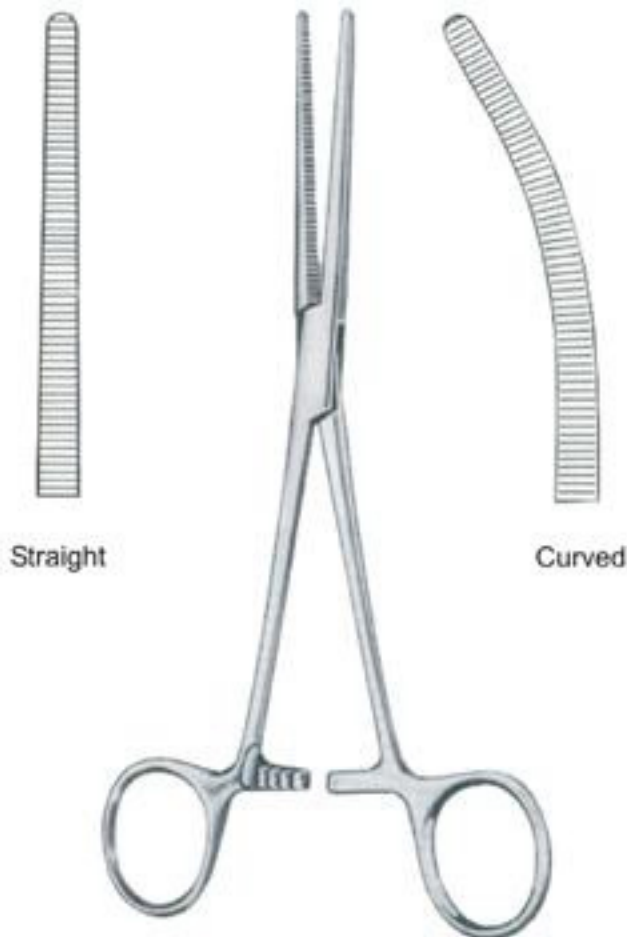

Rochester-Pean		cm	in	Ochsner-Kocher	
9-0191-13	9-0192-13	13.0	5"	9-0195-13	9-0196-13
9-0191-14	9-0192-14	14.0	5 1/2"	9-0195-14	9-0196-14
9-0191-16	9-0192-16	16.0	6 1/4"	9-0195-16	9-0196-16
9-0191-18	9-0192-18	18.0	7"	9-0195-18	9-0196-18
9-0191-20	9-0192-20	20.0	8"	9-0195-20	9-0196-20
9-0191-22	9-0192-22	22.0	8 3/4"	9-0195-22	9-0196-22
9-0191-24	9-0192-24	24.0	9 1/2"	9-0195-24	9-0196-24
9-0191-26	9-0192-26	26.0	10 1/4"	9-0195-26	9-0196-26
9-0191-30	9-0192-30	30.0	12"	9-0195-30	9-0196-30



Kronlein
9-0199-13
13cm/5"



Brand
9-0202-15 15cm/6"
9-0202-19 19cm/7 1/2"
9-0202-24 24cm/9 1/2"



Brand
9-0204-15 15cm/6"
9-0204-19 19cm/7 1/2"
9-0204-24 24cm/9 1/2"



9-0207-16
9-0207-20

9-0208-16
9-0208-20

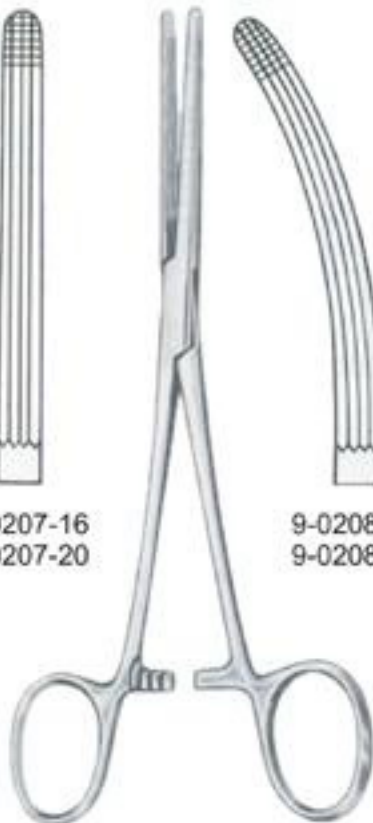

Rochester-Carmalt
16cm/6 1/4"
20cm/8"

Lateral Curved

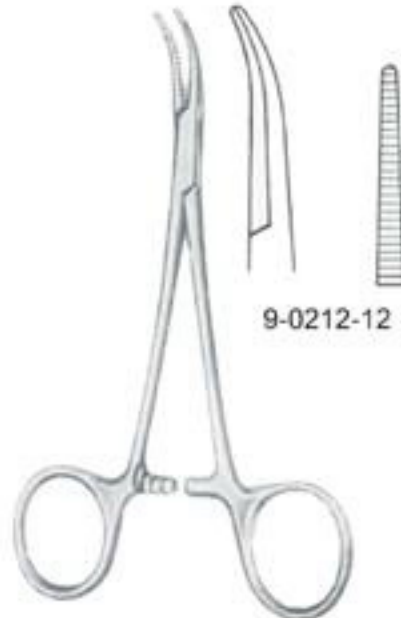

Mosquito-Dandy
12cm/4 3/4"

9-0212-12



9-0214-12



Dandy
14cm/5 1/2"

9-0218-14

9-0220-14



Lovelace
9-0223-15
15.5cm/6"



Dixon-Lovelace
9-0227-16
16cm/6¼"



Dixon-Lovelace
9-0231-16
16cm/6¼"



Bainbridge
15cm/6"
18cm/7"



9-0235-15
9-0235-18



9-0236-15
9-0236-18



Fuchsig
9-0239-19
19cm/7½"





Adson
18.5cm/7¼"

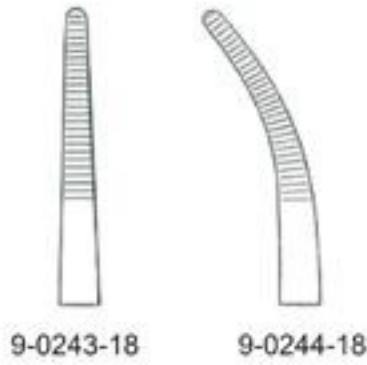

9-0243-18 9-0244-18

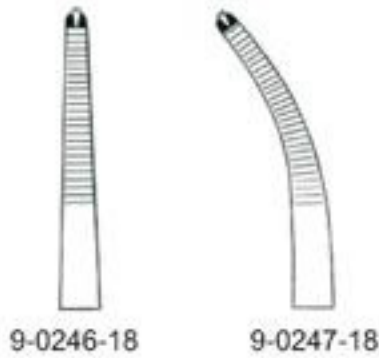

9-0246-18 9-0247-18



Nissen
9-0248-18 18.5cm/7¼"
9-0248-22 22.0cm/8¾"



Baby-Adson



9-0252-14
14cm/5½"



9-0254-18
18cm/7"

Very Fine



Jacobson-Adson
18cm/7"



9-0257-18



9-0258-18



9-0260-18

General Instruments

Hemostatic Forceps



Schmidt
19cm/7½"

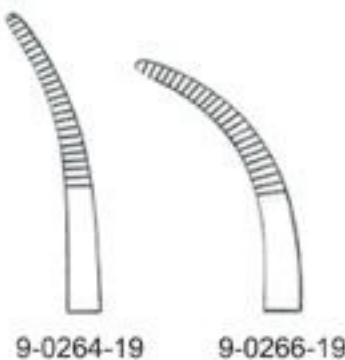

9-0264-19 9-0266-19



Schmidt
19cm/7½"

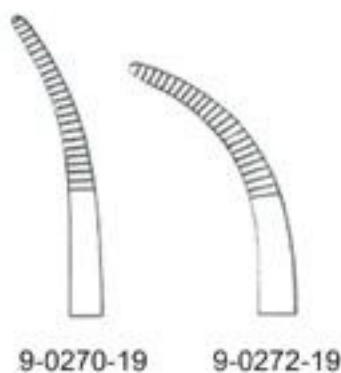

9-0270-19 9-0272-19



Birkett
19cm/7½"

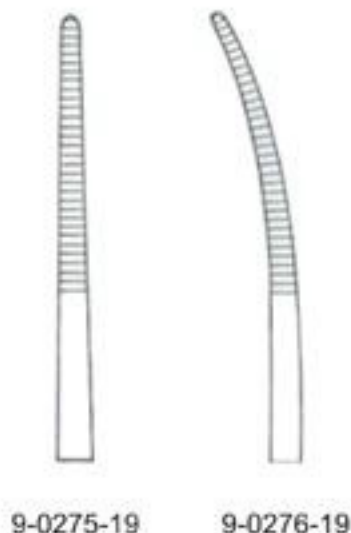

9-0275-19 9-0276-19



Bengolea



20cm/8"	9-0279-20	9-0280-20	9-0283-20	9-0284-20
22cm/8¾"	9-0279-22	9-0280-22	9-0283-22	9-0284-22
24cm/9½"	9-0279-24	9-0280-24	9-0283-24	9-0284-24
26cm/10¼"	9-0279-26	9-0280-26	9-0283-26	9-0284-26



Bridge
 27cm/10½"



9-0289-27



9-0290-27



Roberts
 22cm/8¾"



9-0295-22



9-0296-22



Kelly



19cm/7½"
 22cm/8¾"
 24cm/9½"

9-0300-19
 9-0300-22
 9-0300-24



9-0302-19
 9-0302-22
 9-0302-24

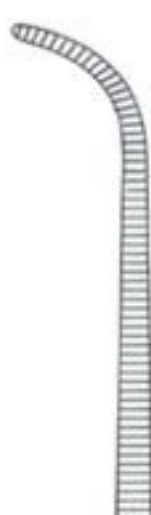

9-0304-19
 9-0304-22
 9-0304-24



Crafoord-Sellors

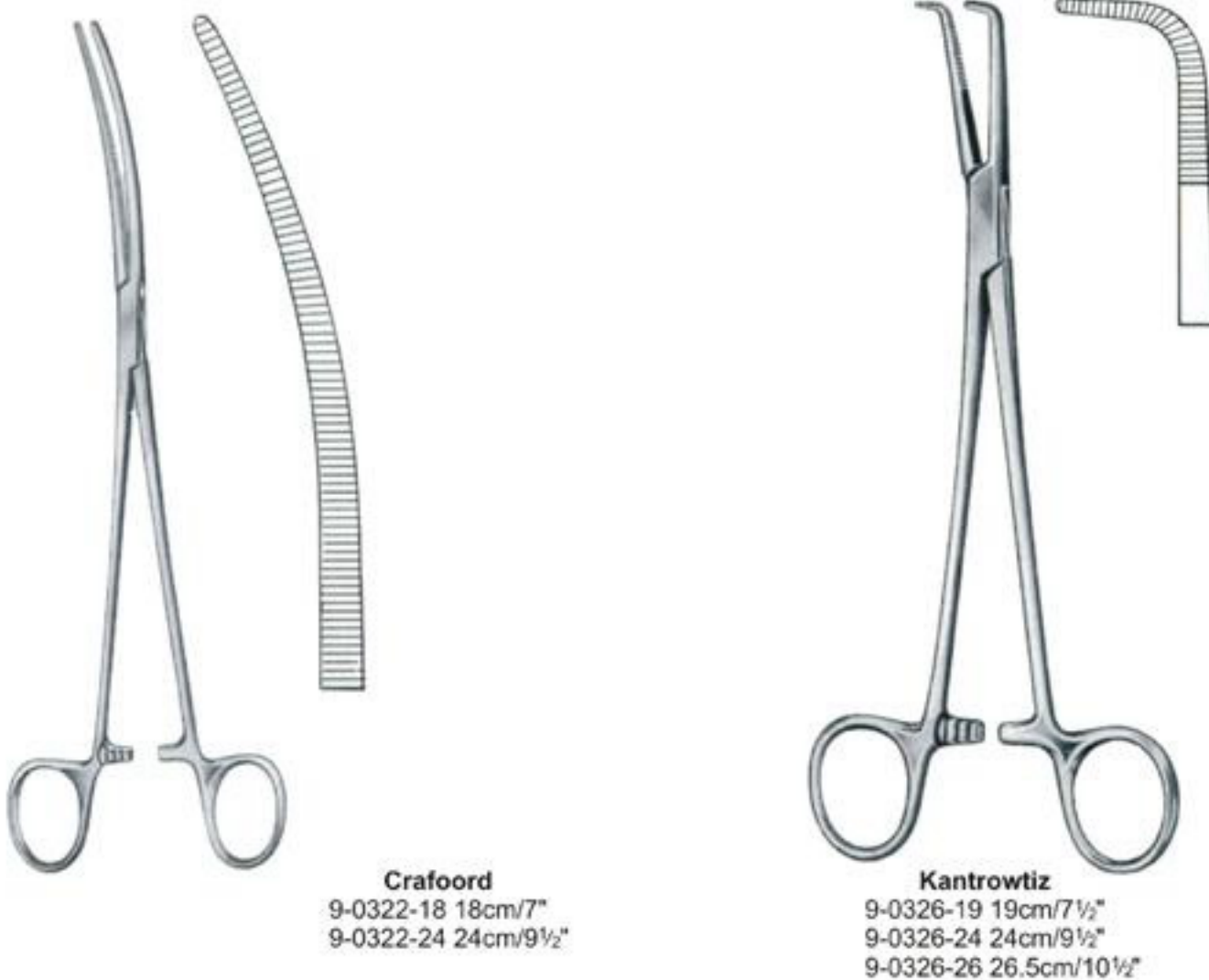



Rumel
23cm/9"



9-0330-23



9-0332-23



9-0334-23

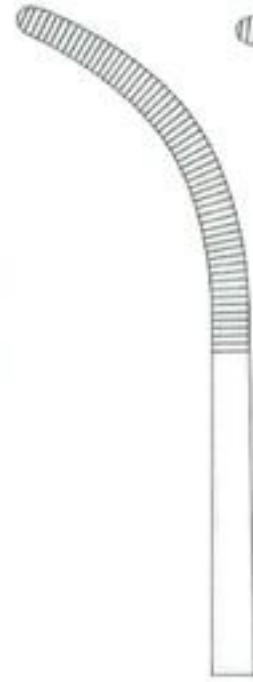

9-0336-23

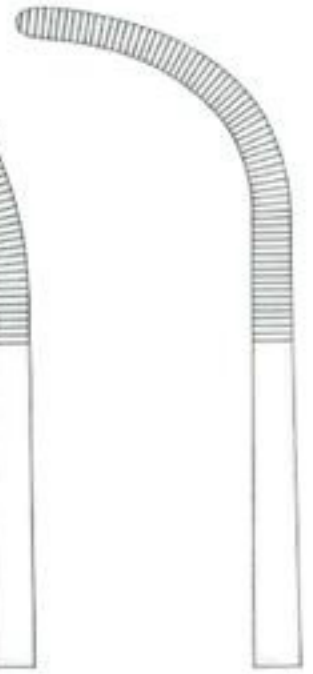

9-0338-23



Johns Hopkins
9-0342-20
20cm/8"



Zenker
29.5cm/11½"



9-0347-29



9-0348-29



9-0350-29

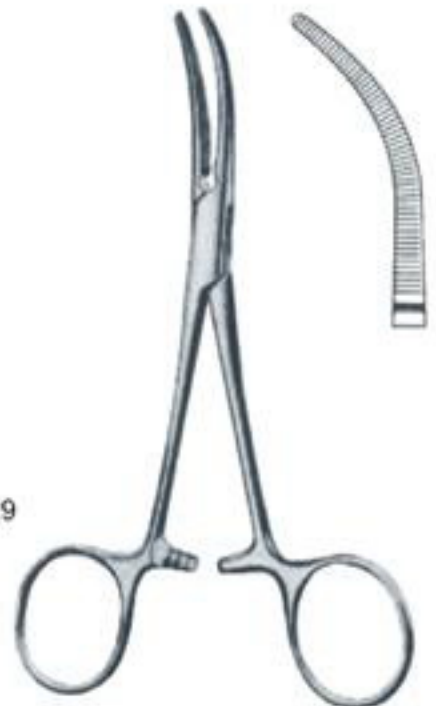

Baby-Overholt
9-0354-13
13.5cm/5¼"



Overholt-Slim



9-0358-18
18.5cm/7 1/4"



9-0360-20
20.5cm/8"

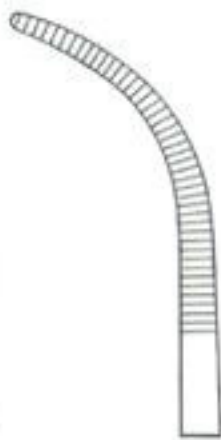

9-0362-21
21cm/8 1/4"

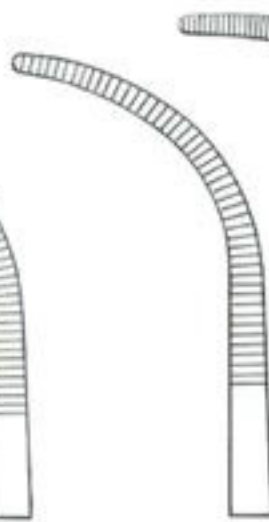

9-0364-21
21.5cm/8 1/2"

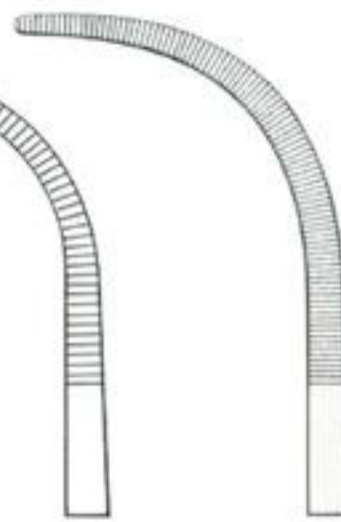

9-0366-24
24cm/9 1/2"



Overholt-Slim



9-0370-18
18.5cm/7 1/4"



9-0372-20
20.5cm/8"



9-0374-21
21cm/8 1/4"

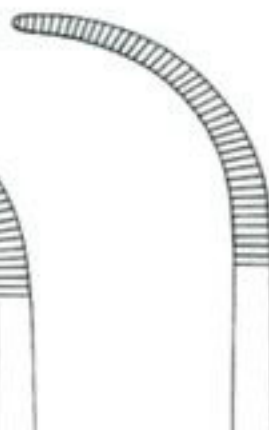

9-0376-21
21.5cm/8 1/4"





Overholt-Geissendorfer
21cm/8¼"
27cm/10½"

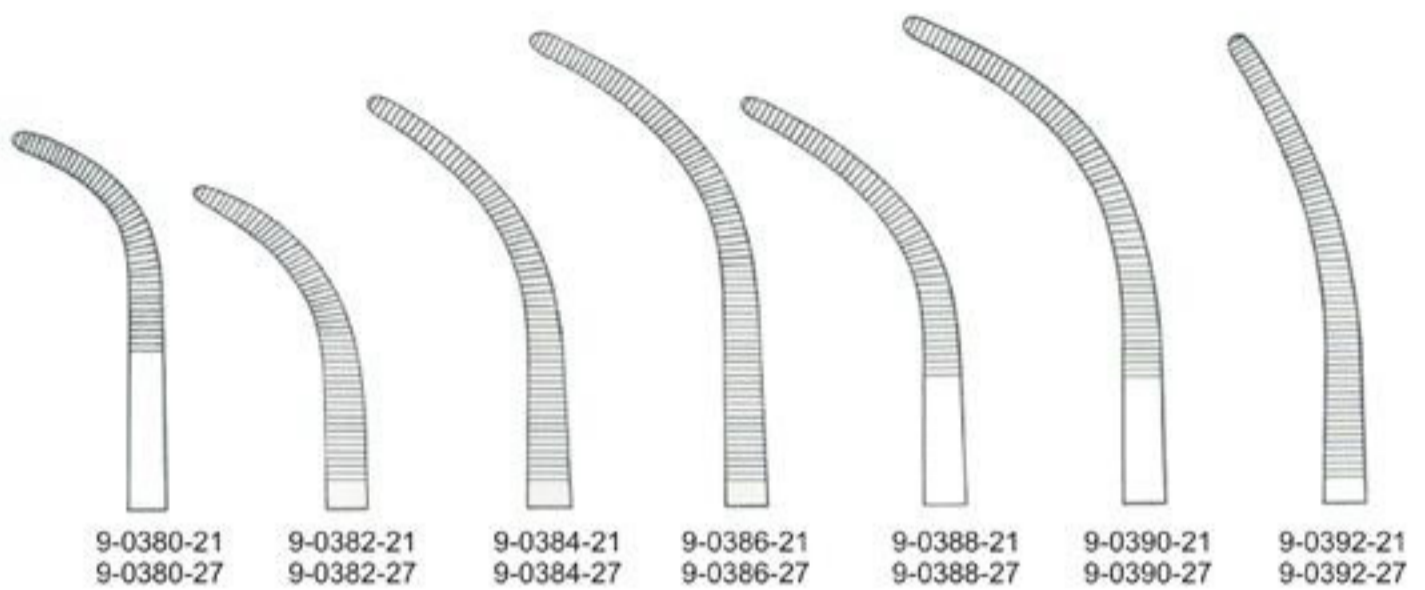

Overholt-Mixter
9-0396-21
21cm/8¼"

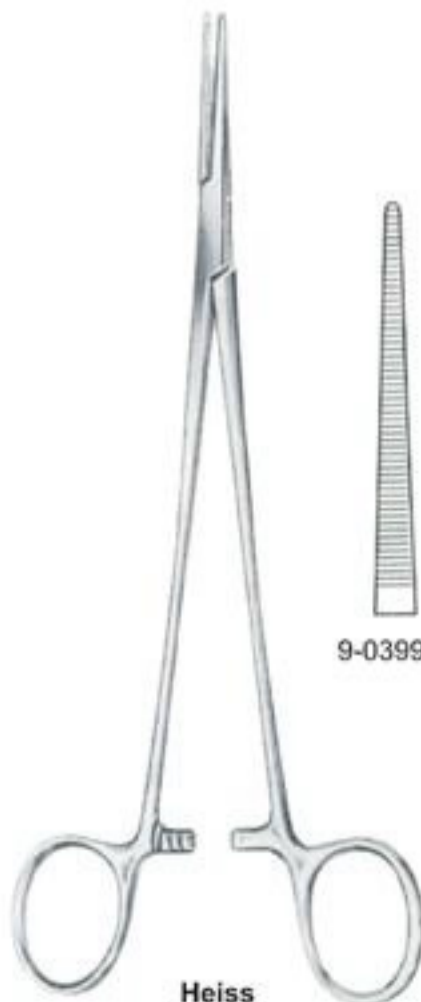

Heiss
20cm/8"

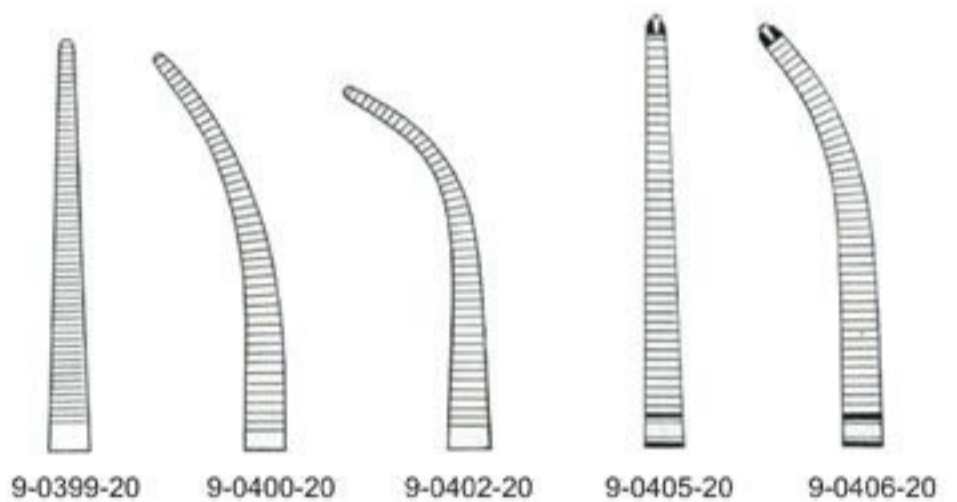



Meeker
9-0408-27
27 cm/10½"



Toennis
21 cm/8¼"
26 cm/10¼"



Lower
9-0418-18
18 cm/7"



Gemini

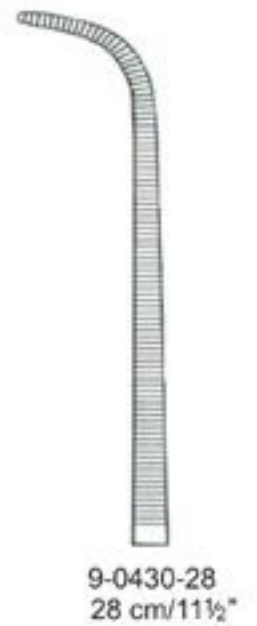
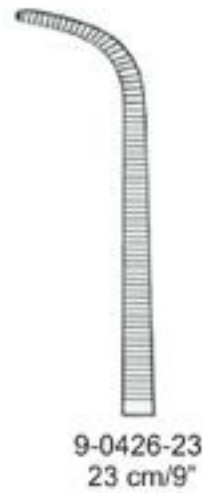



Mini-Gemini

9-0432-18
18 cm/7"

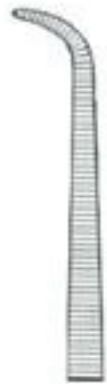

9-0434-22
22 cm/8 3/4"

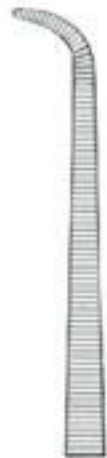

9-0436-25
25 cm/10"



9-0438-28
28 cm/11"



Baby-Mixer

14 cm/5 1/2"
18 cm/7"



9-0444-14
9-0444-18



9-0446-14
9-0446-18



Mixer

9-0450-15 15 cm/6"
9-0450-19 19 cm/7 1/2"



Mixer-O'Shaugnessy

9-0454-15 15.5 cm/6"
9-0454-19 19.0 cm/7 1/2"

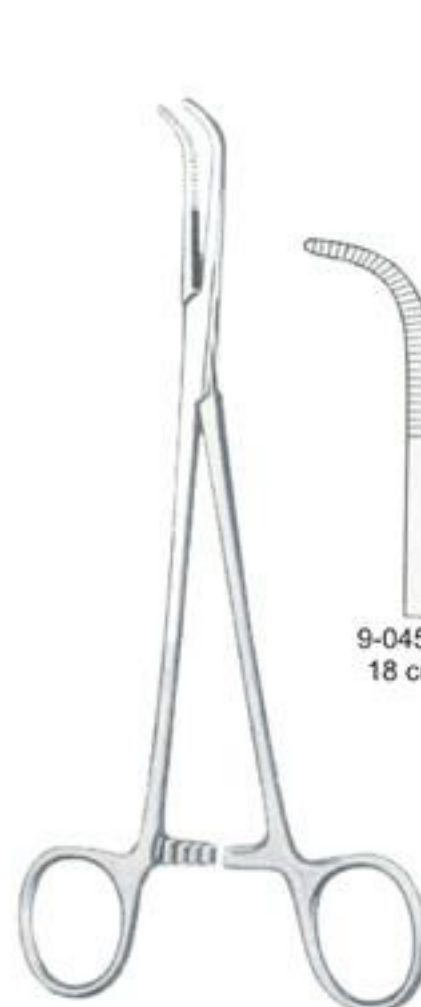

Mixer-Slim

9-0458-18
18 cm/7"



9-0460-23
23 cm/9"



9-0464-22
 22 cm/8¾"

Mixer



9-0466-25
 25 cm/10"

9-0468-28
 28 cm/11"



Mixer
 9-0472-22
 22 cm/8¾"



Wickstroem
 9-0476-20
 20 cm/8"



Finocchietto
 9-0480-24
 24 cm/9½"

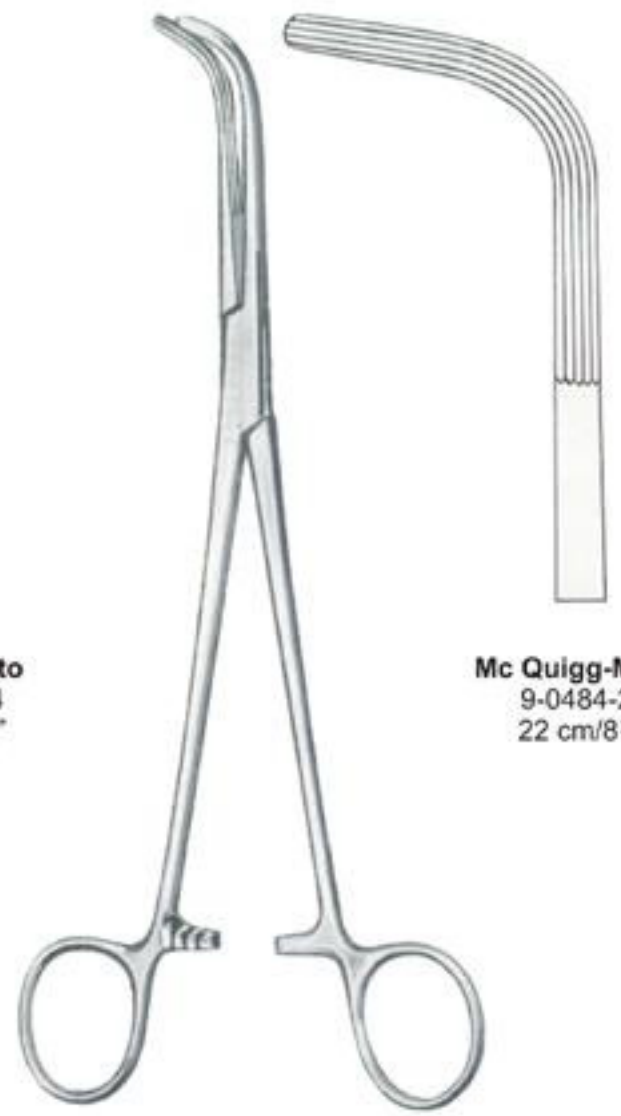

Mc Quigg-Mixer
 9-0484-22
 22 cm/8¾"



Lawrence
9-0488-27
27.5 cm/10¾"



Lahey (Sweet)

9-0492-19
19 cm/7½"

9-0494-23
23 cm/9"



Spencer-Wells

- | | | |
|-----------|----------|-----------|
| 9-0499-13 | 13 cm/5" | 9-0500-13 |
| 9-0499-15 | 15 cm/6" | 9-0500-15 |
| 9-0499-18 | 18 cm/7" | 9-0500-18 |
| 9-0499-20 | 20 cm/8" | 9-0500-20 |
| 9-0499-23 | 23 cm/9" | 9-0500-23 |



Spencer-Wells

- | | | |
|-----------|-----------|-----------|
| 9-0503-13 | 13 cm/5" | 9-0504-13 |
| 9-0503-14 | 14 cm/5½" | 9-0504-14 |
| 9-0503-15 | 15 cm/6" | 9-0504-15 |
| 9-0503-18 | 18 cm/7" | 9-0504-18 |
| 9-0503-20 | 20 cm/8" | 9-0504-20 |
| 9-0503-23 | 23 cm/9" | 9-0504-23 |



Rogers



9-0507-22
 22.5 cm/9"
 9-0507-25
 25.0 cm/10"



9-0508-22
 22.0 cm/8³/₄"
 9-0508-24
 24.5 cm/9³/₄"



9-0510-21
 21.5 cm/8¹/₂"
 9-0510-24
 24.0 cm/9¹/₂"



9-0512-20
 20.5 cm/8"
 9-0512-23
 23.5 cm/9"



Heaney



19.5 cm/7¹/₂" 9-0516-19
 21.5 cm/8¹/₄" 9-0516-21
 23.5 cm/9" 9-0516-23



9-0518-19
 9-0518-21
 9-0518-23



Heaney-Slim
 9-0522-21
 21 cm/8¹/₄"



Ballentine
9-0529-21
21cm/8¼"



Heaney-Ballentine
9-0530-21
21cm/8¼"



Tonsil Forceps



Fig. 1

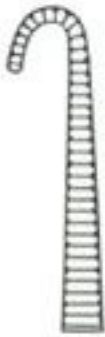

Fig. 2

Negus
9-0534-19 19cm/7½" 9-0536-19



Phaneuf
21.5cm/8½"



9-0541-21

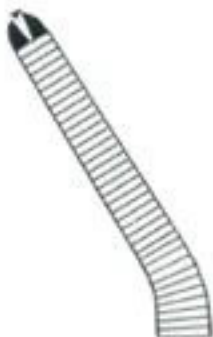

9-0542-21



Haemorrhoidal Clamps

Straight
16cm/6¼" 9-0546-16
20cm/8" 9-0546-20

Curved
9-0548-16
9-0548-20



Fergusson

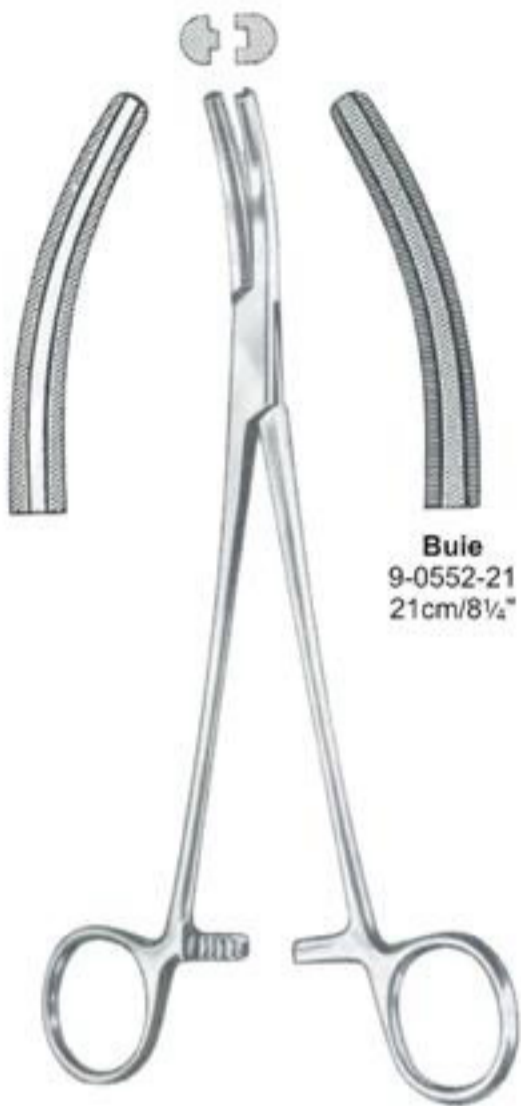

Bule
9-0552-21
21cm/8¼"



Long
9-0556-19
19cm/7½"



Garland
9-0560-21
21cm/8¼"

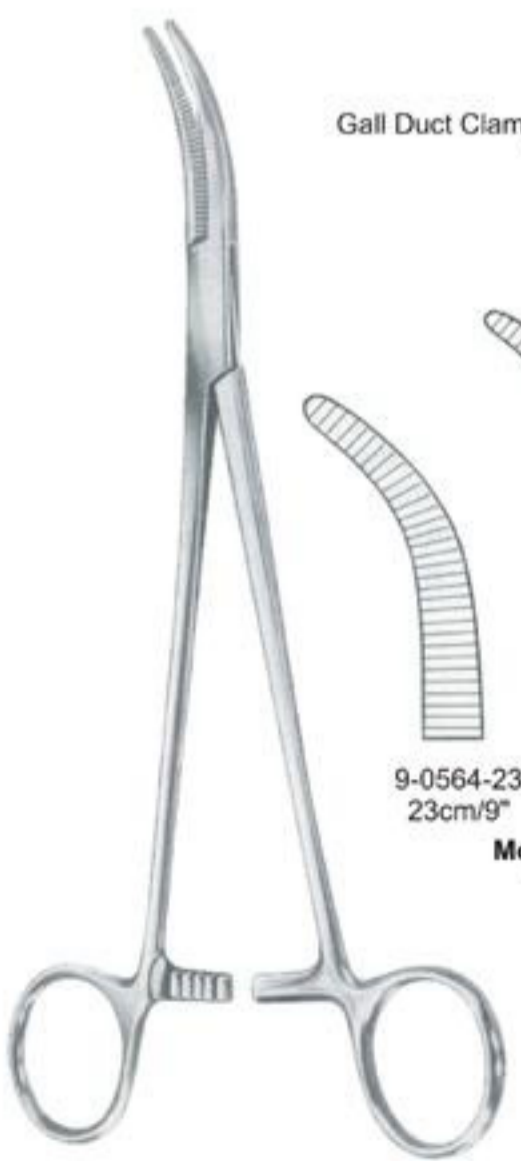

Gall Duct Clamps

Moynihan
9-0564-23 23cm/9"
9-0566-24 24cm/9½"



Hysterectomy Forceps

Hozibach
9-0569-23 23.5cm/9¼"
9-0570-23



Pressure Clamps

Zweifel
9-0574-17
17.5cm/7"

Scalp Flap Forceps



Martel
9-0578-14
14cm/5½"

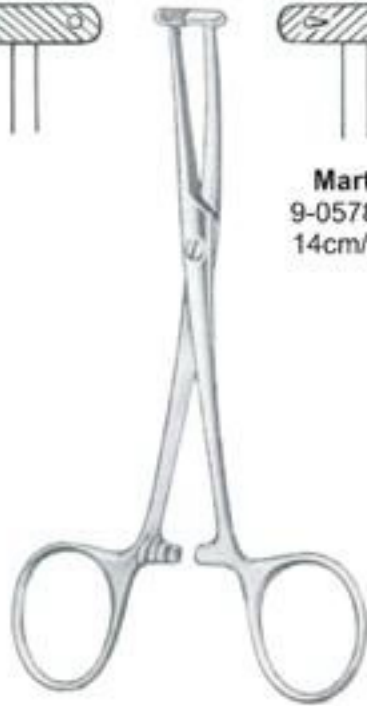

Wertheim
9-0582-25
25cm/10"

Extra Strong



Wertheim-Cullen
9-0586-21
21.5cm/8½"



Wertheim
9-0590-24
24cm/9½"



Faure
 9-0596-25
 25cm/10"



23cm/9"

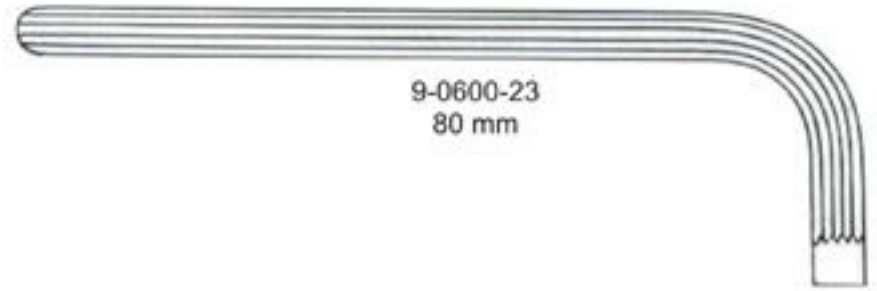

9-0600-23
 80 mm

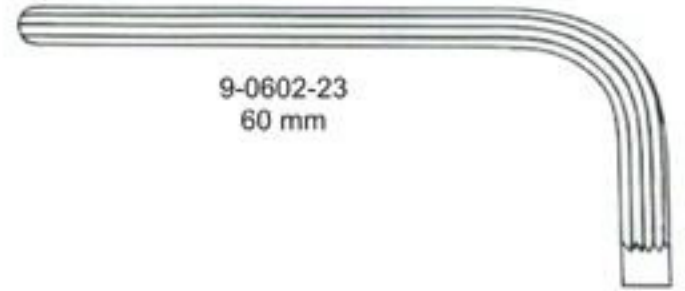

9-0602-23
 60 mm



Wertheim
 22cm/8¾"



Slightly Curved
 9-0606-22



More Curved
 9-0608-22



Wertheim
 9-0612-22
 22cm/8¾"



Wertheim
9-0616-18
18 cm/7"



Baby-Mikulicz
9-0620-14
14 cm/5½"



Mikulicz
9-0624-18 18cm/7"
9-0624-20 20cm/8"



Mikulicz
9-0628-20
20 cm/8"



Mikulicz
9-0632-18
18.5 cm/7¼"

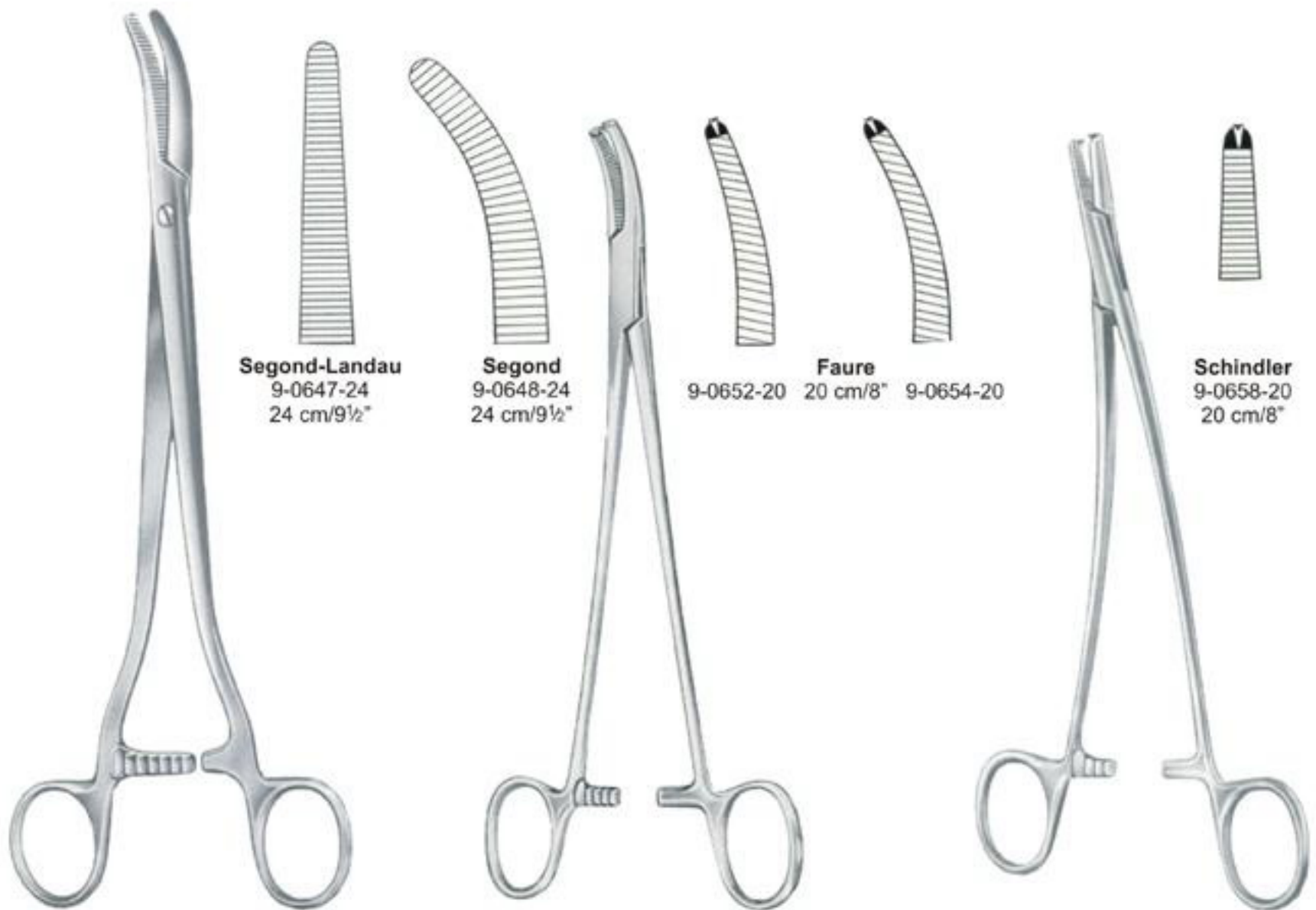



Schadel
9-0662-09 9 cm/3½"



Jones
9-0666-05 5 cm/2"
9-0666-09 9 cm/3½"



Engl-Modell
9-0670-09 9 cm/3½"



Backhaus
9-0674-09 9 cm/3½"
9-0674-11 11 cm/4½"
9-0674-13 13 cm/5"
9-0674-15 15 cm/6"

With clip for Tubing or Cable



9-0678-11 11 cm/4½"
9-0678-13 13 cm/5"



Peers-Bertram
9-0682-14 14.5 cm/5¾"



Tohoku
9-0686-10 10 cm/4"
9-0686-13 13 cm/5"



Ball and socket
9-0690-10 10 cm/4"
9-0690-13 13 cm/5¼"



Roeder
9-0694-13 13 cm/5"
9-0694-15 15 cm/6"



Lorna
9-0698-10 10 cm/4"
9-0698-13 13 cm/5"



Bernhard
9-0703-16 16.5 cm/6½"



Lane
9-0707-13 13cm/5"
9-0707-15 15cm/6"
9-0707-18 18cm/7"
9-0707-20 20cm/8"
20 cm/8"



Doyen
9-0711-18
18 cm/7"



9-0715-14 14 cm/5½"
9-0715-15 15 cm/6"
9-0715-18 18 cm/7"
9-0715-20 20 cm/8"



9-0719-14
14.5 cm/5¾"

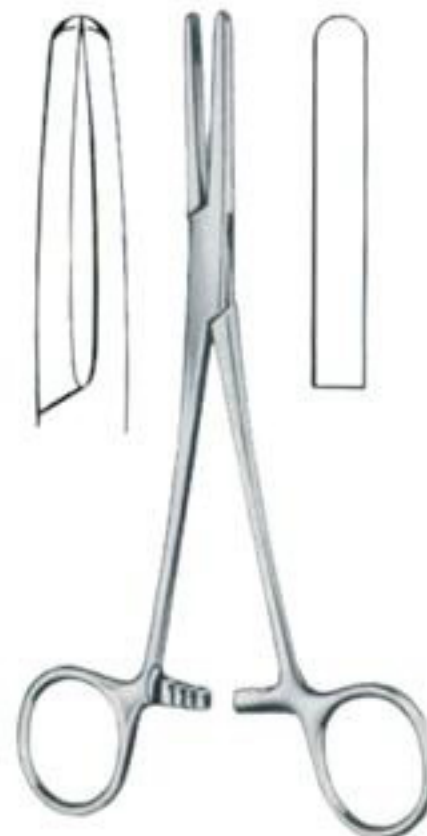

9-0721-16 16.5 cm/6½"
9-0721-18 18.0 cm/7"



9-0725-15 15 cm/6"
9-0725-18 18 cm/7"
9-0725-20 20 cm/8"



Mohr
9-0729-50 50 mm
9-0729-60 60 mm
9-0729-70 70 mm
9-0729-80 80 mm

Sizes
mm
13
17
20
25
30



Hoffmann
9-0731-13
9-0731-17
9-0731-20
9-0731-25
9-0731-30



Hoffmann
9-0733-13
9-0733-17
9-0733-20
9-0733-25
9-0733-30



Ulrich

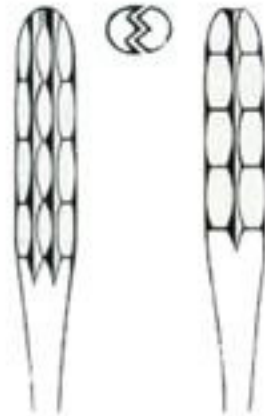

Straight

10-0005-22
10-0005-25
10-0005-27

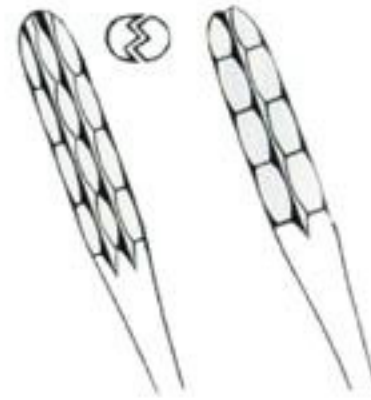

Curved

22 cm/8¾"
25 cm/10"
27 cm/10½"

10-0006-22
10-0006-25
10-0006-27



Lister

10-0009-13
10-0009-15
10-0009-18

13 cm/5"
15 cm/6"
18 cm/7"

10-0011-13
10-0011-15
10-0011-18



Bryant

10-0016-13
13 cm/5"

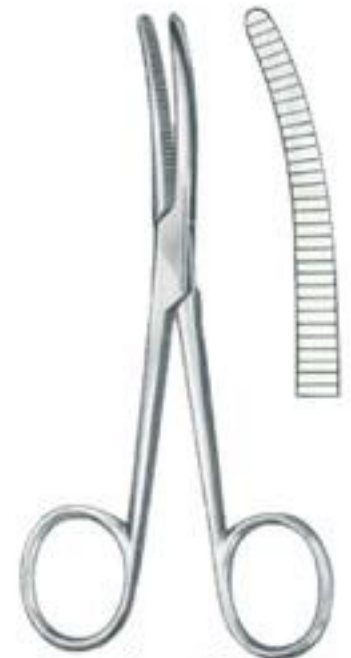

Bryant

10-0018-13
13 cm/5"



Gross-Maier

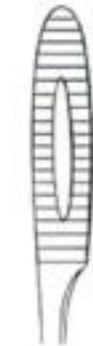

Straight



Curved

With Ratchet

10-0025-20
 10-0025-25

20 cm/8"
 25 cm/10"

10-0026-20
 10-0026-25

Without Ratchet

10-0029-20
 10-0029-25

20 cm/8"
 25 cm/10"

10-0030-20
 10-0030-25



Pelkman
 25 cm/10"



Sims-Maier
 28 cm/11"



Duplay
 20 cm/8"





Collin
10-0051-25
25cm/10"
10-0053-25 B/J
25cm/10"



Cheron
10-0055-25
25cm/10"
10-0057-25 B/J
25cm/10"



Emmet
10-0059-21
21cm/8¼"



Bozemann
10-0063-26
26cm/10¼"



Bozemann
26cm/10¼"



10-0068-26



Smooth

10-0070-26



Bozemann-Douglas
10-0074-26
26cm/10¼"



Rampley
10-0079-18 18cm/7"
10-0079-24 24cm/9½"



Rampley
10-0083-18 18cm/7"
10-0083-24 24cm/9½"



10-0085-24
24 cm/9½"



Foerster

18 cm/7"
20 cm/8"
24 cm/9½"
25 cm/10"



10-0087-18
10-0087-20
10-0087-24
10-0087-25

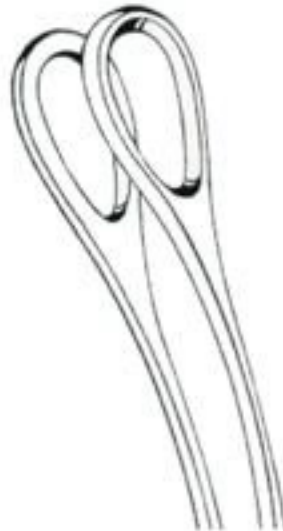

10-0088-18
10-0088-20
10-0088-24
10-0088-25



10-0095-18
10-0095-20
10-0095-24
10-0095-25

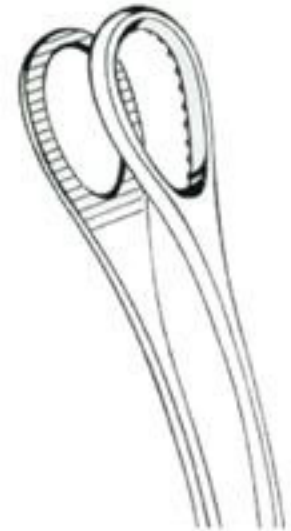

10-0096-18
10-0096-20
10-0096-24
10-0096-25



Schwartz
10-0100-19
19cm/7½"



10-0105-01



10-0106-02



10-0108-03



Applying Forceps

10-0112-23
23cm/9"



Diethrich



10-0117-08



10-0117-12



10-0117-20



10-0118-08



10-0118-12



10-0118-20

Atrauma



10-0123-10



10-0123-14



10-0123-20



10-0124-10



10-0124-14



10-0124-20

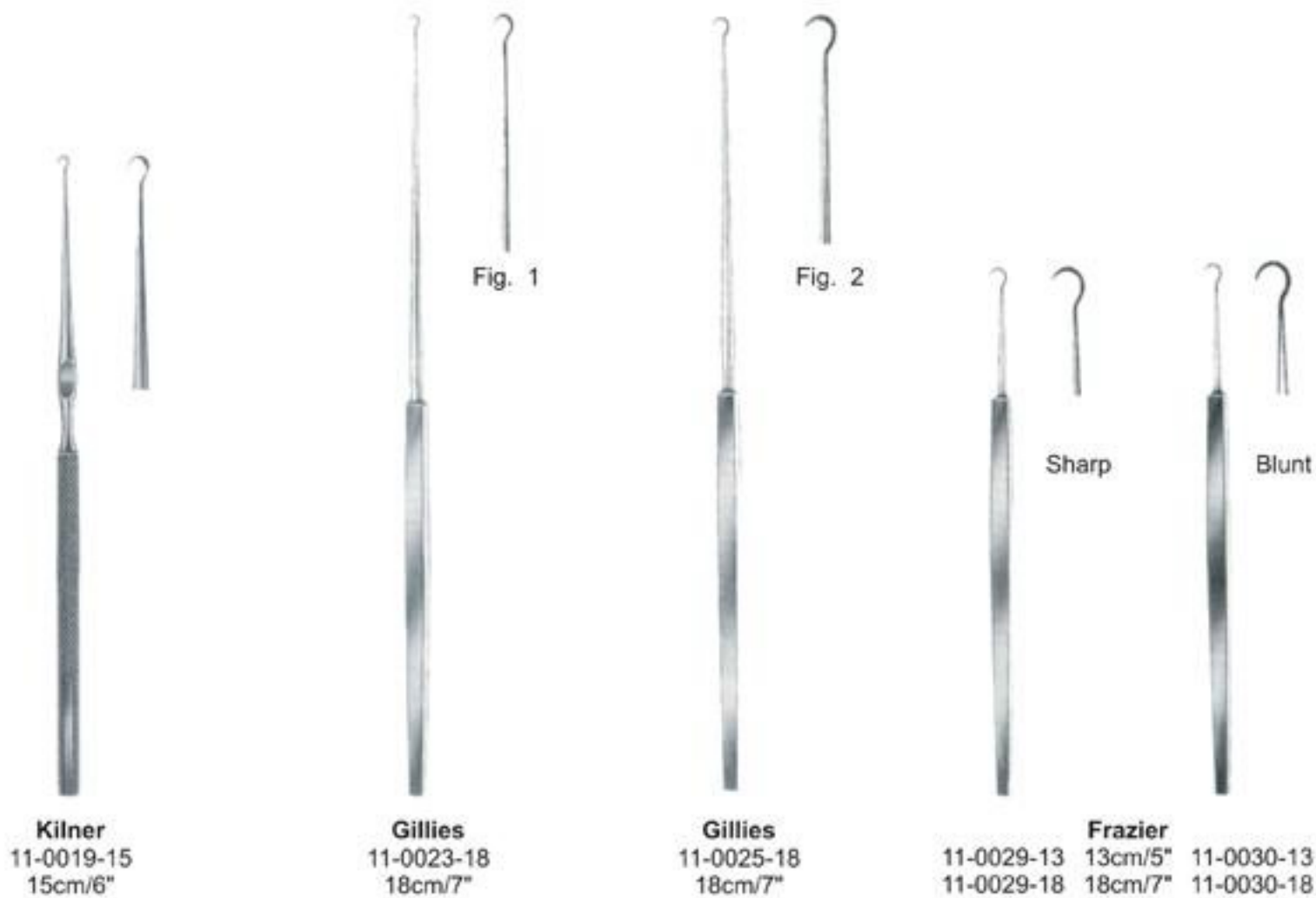
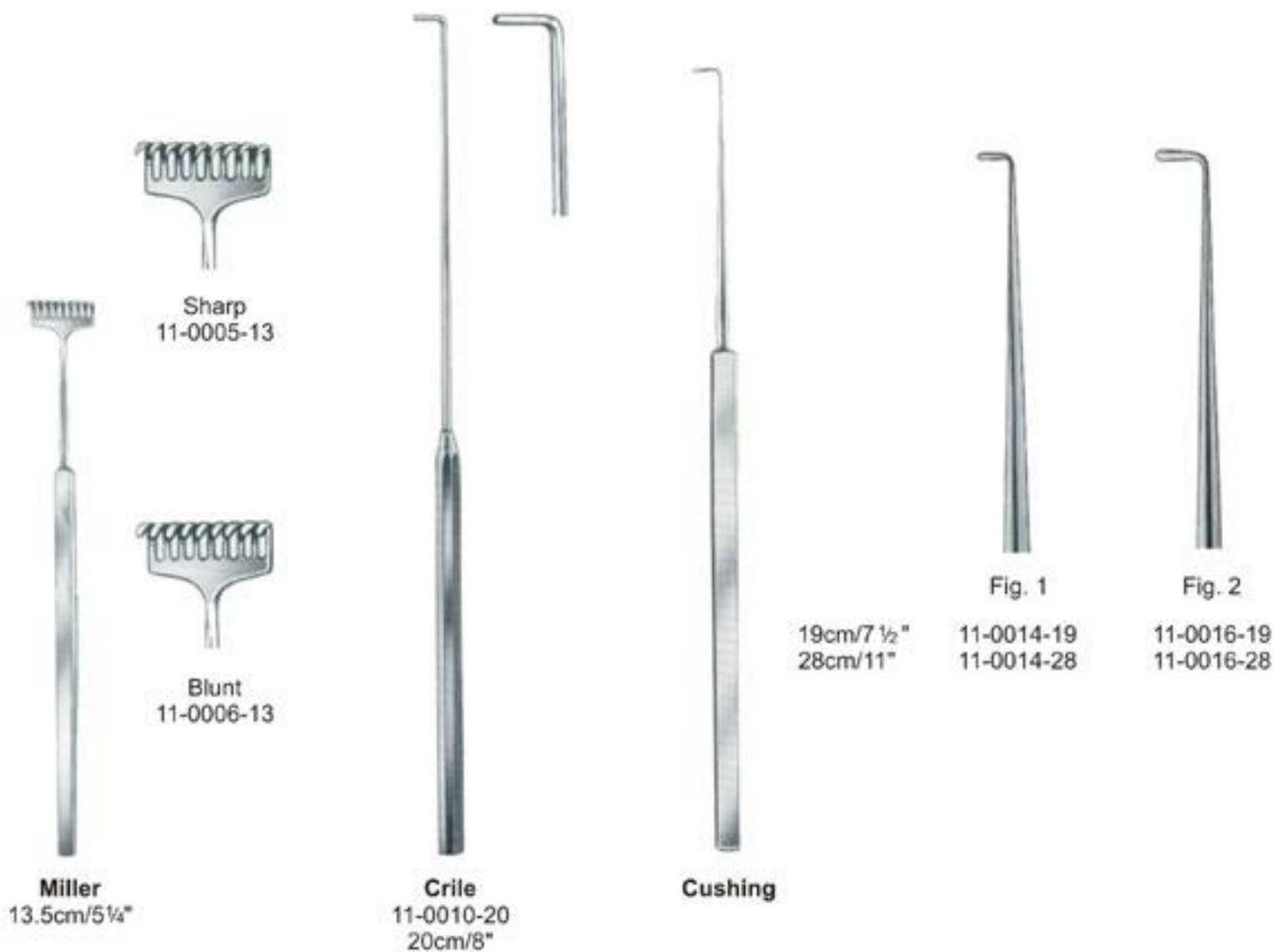



Graefe
11-0045-16 16cm/6¼" 11-0046-16



Guthrie
11-0057-16 16cm/6¼" 11-0059-16



11-0063-16
16cm/6¼"

11-0065-16
16cm/6¼"



Malleable



Gil-Vernet
24cm/9½"

8 mm 11-0090-08	11-0092-08
11 mm 11-0090-11	11-0092-11
15 mm 11-0090-15	11-0092-15
17 mm 11-0090-17	11-0092-17
20 mm 11-0090-20	11-0092-20
23 mm 11-0090-23	11-0092-23

Malleable



24cm/9½"

12x14 mm



Little
11-0096-20
20cm/8"



Love-(Morse)
25cm/10"

- 10 mm 11-0100-10
- 15 mm 11-0100-15
- 20 mm 11-0100-20
- 30 mm 11-0100-30
- 40 mm 11-0100-40
- 50 mm 11-0100-50

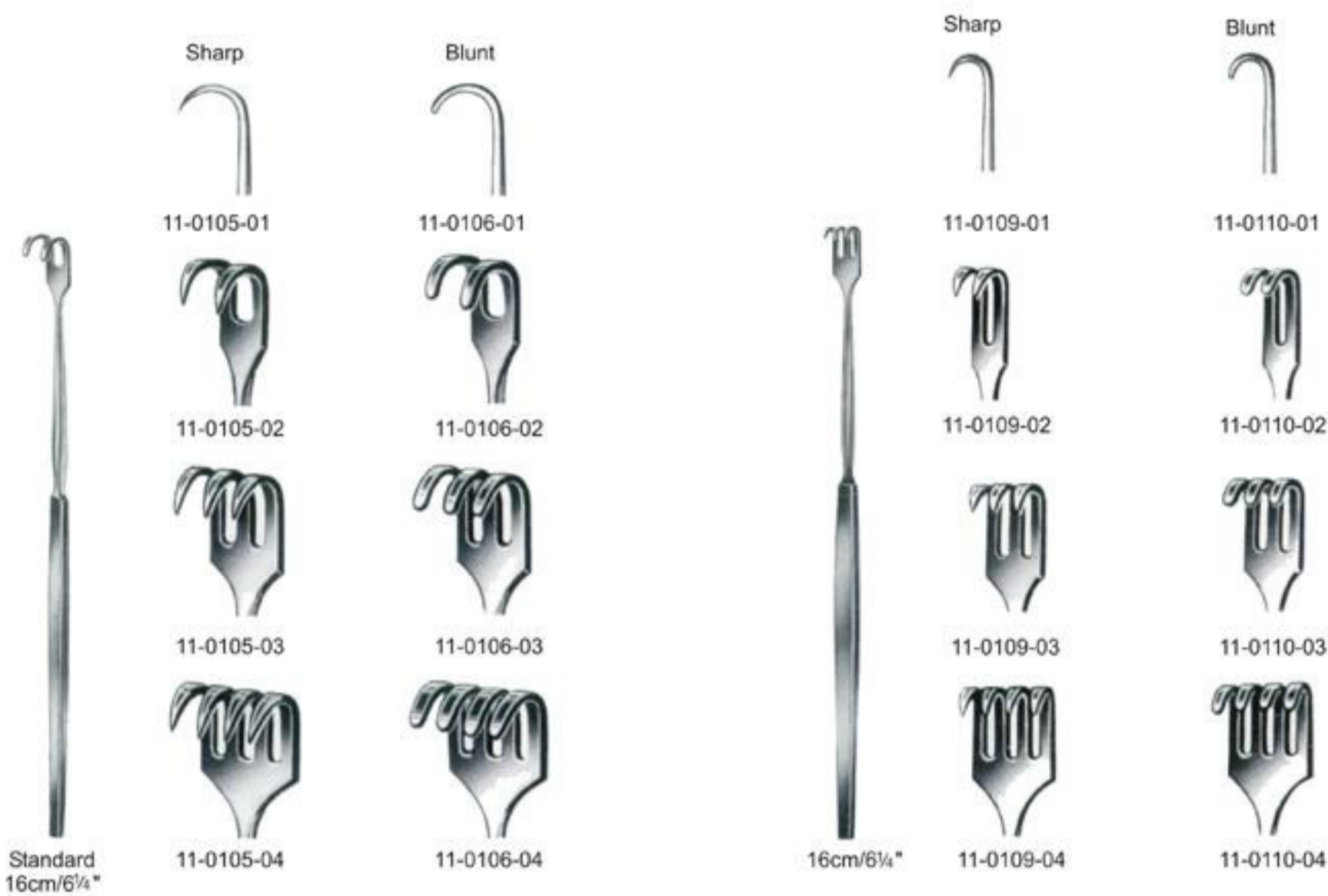



11-0120-13
13.5cm/5¼"



Jackson
11-0125-13
13cm/5"



Bergmann
11-0129-14
14cm/5½"



Iterson
16cm/6¼"



11-0133-16



11-0134-16



Meyerding
18cm/7"



11-0138-18
18x7 mm



11-0144-18
16x5 mm



11-0140-18
7x4 mm



11-0146-18
10x3 mm



11-0142-18
7x4 mm



11-0148-18



Volkman
11.5cm/4½"



Sharp
11-0153-02



Blunt
11-0154-02



11-0153-03



11-0154-03



11-0153-04



11-0154-04



11-0153-06



11-0154-06

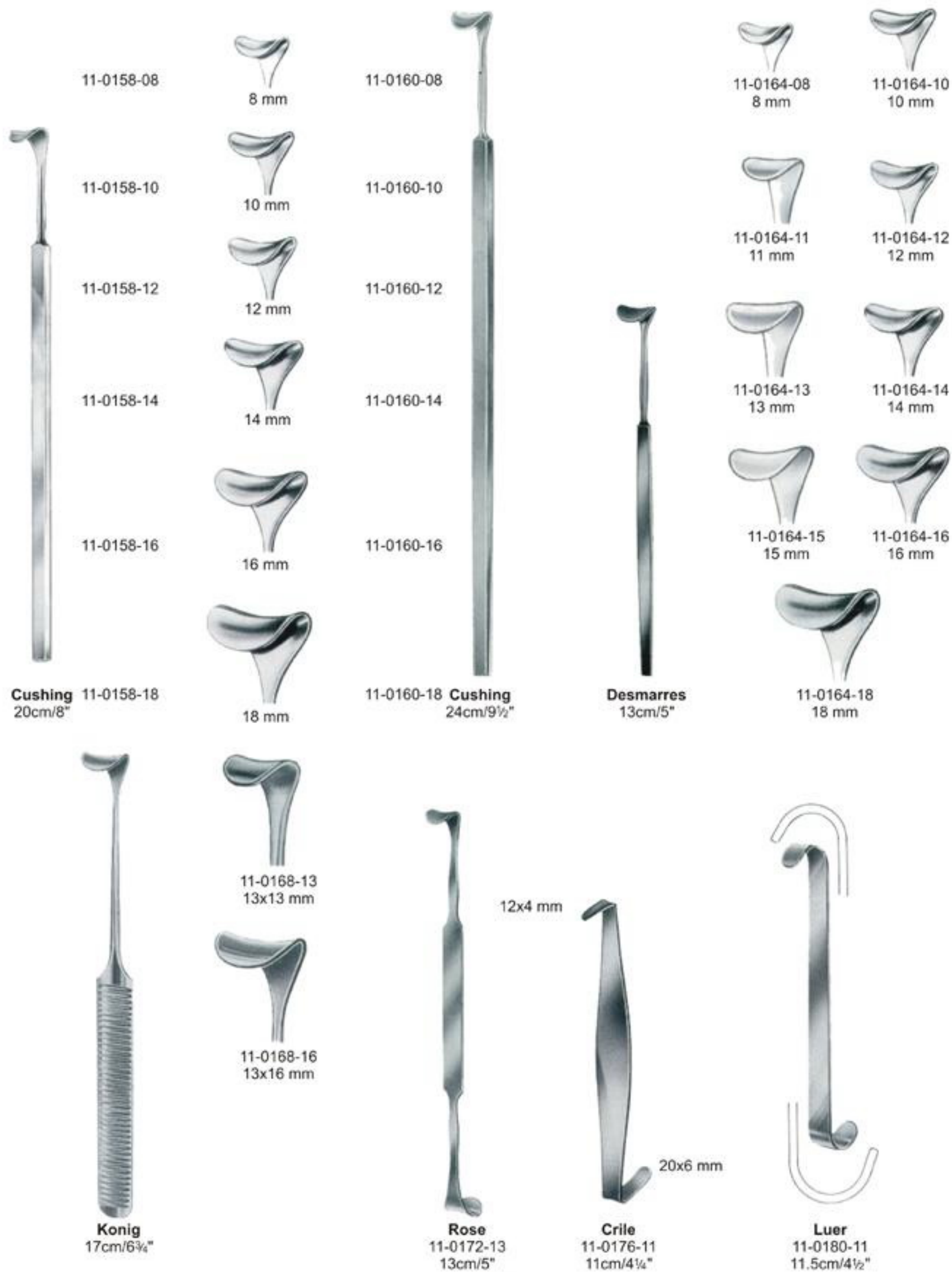



10x10 mm

Cushing-Kocher
 11-0184-18
 18cm/7"



Langenbeck-Green
 17cm/6 3/4"



11-0186-17
 6x25 mm

11-0188-17
 8x25 mm



Strandell-Stille
 19cm/7 1/2"



11-0190-19



11-0192-19

toothed

Tendon Sheath Hook



Klapp
 17.5 cm/7"



11-0196-01



11-0196-02



11-0196-03

Decompression Hook



Cushing
 11-0200-20
 20cm/8"



Senn-Miller
16cm/6¼"



Baby-Senn-Miller
16cm/6¼"



Rangell-Davis
11-0214-14
14cm/5½"



Senn-Green
15cm/6"



Langenbeck-Green
16cm/6¼"



Collin-Hartmann



Roux



Baby-Roux
13 cm/5"



Mini-Roux
14 cm/5½"

Set	11-0228-00	Set	11-0232-00	11-0236-13	11-0240-14
14 cm/5½"	11-0228-01	14 cm/5½" Fig. 1	11-0232-01		
16 cm/6"	11-0228-02	15 cm/6" Fig. 2	11-0232-02		
		17 cm/6¾" Fig. 3	11-0232-03		

37x40 mm



Goelet
11-0244-19
19 cm/7½"



Parker-Langenbeck (US-Army)
11-0248-21
21cm/8¼"

Set



Parker
11-0252-13
13.5 cm/5¼"

Set



Parker
11-0254-18
18 cm/7"

Set

37x31 mm



Set

Parker-Mott
11-0258-16
16 cm/6 1/4"



Set

Farabeuf
11-0262-12
12 cm/4 3/4"



Set

Farabeuf
11-0264-15
15 cm/6"



Farabeuf
11-0266-01
8x10x100mm
11-0266-02
7x9x120mm
11-0266-03
11x14x120mm
11-0266-04
11x15x150mm
11-0266-05
21x15x150mm



Set

Collin
11-0268-16
16.5 cm/6 1/2"



Set

Mayo-Collin
11-0272-15
15 cm/6"



Set

Mathieu
11-0276-19
19 cm/7 1/2"



Volkmann
11-0279-22
22 cm/8 3/4"



Volkmann
11-0280-22
22 cm/8 3/4"



11-0283-23
23 cm/9"



11-0284-23
23 cm/9"



Volkmann
21,5cm/8 1/2"

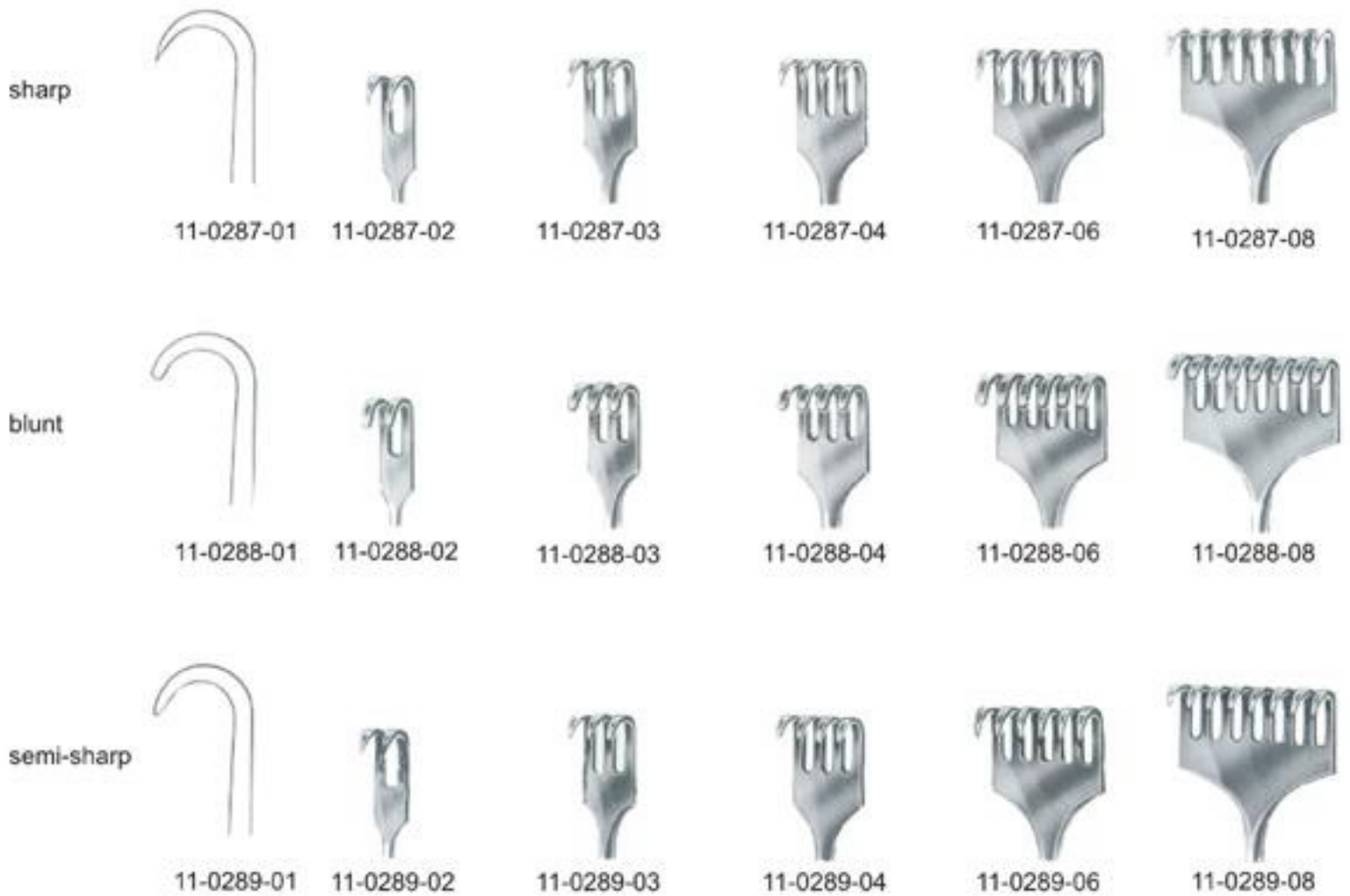



Volkmann
21 cm/8 $\frac{3}{4}$ "

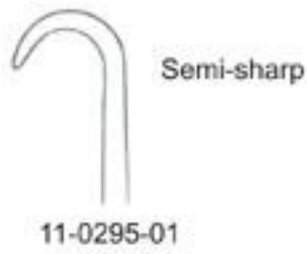



Kocher
22 cm/8³/₄"

sharp



11-0309-01



11-0309-02



11-0309-03



11-0309-04



11-0309-06



11-0309-08

blunt



11-0310-01



11-0310-02



11-0310-03



11-0310-04



11-0310-06



11-0310-08

semi-sharp



11-0311-01



11-0311-02



11-0311-03



11-0311-04



11-0311-06



11-0311-08



sharp



11-0315-20
20 cm/8"



blunt



11-0316-20
20 cm/8"



sharp



11-0321-14
14 cm/5¹/₂"



Ollier
11-0324-02
36x60 mm
22,5 cm/9"

Ollier
11-0324-01
36x30 mm
22,5 cm/9"



Murphy
19.5 cm/7 3/4"

Sharp



11-0327-02



11-0327-03



11-0327-04



11-0327-06

blunt



11-0328-02



11-0328-03



11-0328-04



11-0328-06



33x20 mm

Wassmund
11-0332-20
20cm/8"



11-0334-02
40x50 mm

Israel
25cm/10"



11-0334-01
40x40 mm



11-0334-03
50x60 mm



11-0334-04
70x70 mm



46x55 mm

Vertical Handle
11-0338-23

Koerte
23cm/9"



Koerte-Wagner
11-0335-28
28cm/11"



Koerte
23.5 cm/9 1/4"

40x30 mm



Sharp
11-0339-23

Blunt
11-0343-23

Vertical Handle



11-0347-24
24cm/9 1/2"

50x25 mm



11-0349-25
25cm/10"



11-0356-01
55x20 mm
11-0356-02
60x20 mm
11-0356-03
63x20 mm



11-0360-01
35x7 mm
11-0360-02
35x10 mm
11-0360-03
35x15 mm
11-0360-04
60x20 mm



11-0364-19
28x6 mm



Langenbeck

11-0352-01 22x6mm 21.5cm/8 1/4"
11-0352-02 44x13mm 21.5cm/8 1/4"
11-0352-03 64x25mm 21.5cm/8 1/4"

Langenbeck
21cm/8 1/4"

Langenbeck
21cm/8 1/4"

Lahey
19cm/7 1/2"



22.5cm

Sauerbruch

11-0368-01 45x15 mm
11-0368-02 60x23 mm
11-0368-03 75x20 mm



Langenbeck
21cm/8 1/4"

11-0372-01 30x11 mm
11-0372-02 30x14 mm
11-0372-03 33x14 mm
11-0372-04 30x16 mm
11-0372-05 40x11 mm
11-0372-06 42x13 mm
11-0372-07 50x11 mm

11-0374-01
11-0374-02
11-0374-04
11-0374-05
11-0374-07



Langenbeck
22cm/8 3/4"

11-0378-01 40x10 mm
11-0378-02 40x15 mm
11-0378-03 40x20 mm



Kocher
22cm/8¾"

11-0380-01
19x12 mm
11-0380-02
21x15 mm



Kocher
19cm/7½"

11-0384-01 25x06 mm
11-0384-02 25x08 mm
11-0384-03 35x08 mm
11-0384-04 35x11 mm
11-0384-05 35x15 mm
11-0384-06 42x11 mm
11-0384-07 55x11 mm
11-0384-08 70x14 mm
11-0384-09 80x12 mm
11-0384-10 80x16 mm



Kocher-Langenbeck
21.5cm/8½"



Czerny
11-0386-18
18 cm/7"



Canny Ryall
11-0388-01
16 x 25 mm 19cm/7½"
11-0388-02
19 x 28 mm 19cm/7½"
11-0388-03
25 x 38 mm 20cm/8"



67x17cm

Casper
11-0390-21
21.5cm/8½"



11-0396-01
22x15 mm



11-0396-02
38x20 mm



11-0396-03
67x25 mm



11-0396-04
100x35 mm



11-0392-01
40x18 mm
11-0392-02
60x20 mm
11-0392-03
60x25 mm
11-0392-04
75x30 mm
11-0392-05
75x40 mm



11-0400-01
60x20 mm
11-0400-02
80x30 mm
11-0400-03
100x30 mm
11-0400-04
120x30 mm
11-0400-05
140x30 mm
11-0400-06
140x40 mm

Kocher
23cm/9"



Kocher-Wagner
28cm/11"



Heesel
25cm/10"





130x60 mm

St. Marks
11-0404-29
29cm/11½"

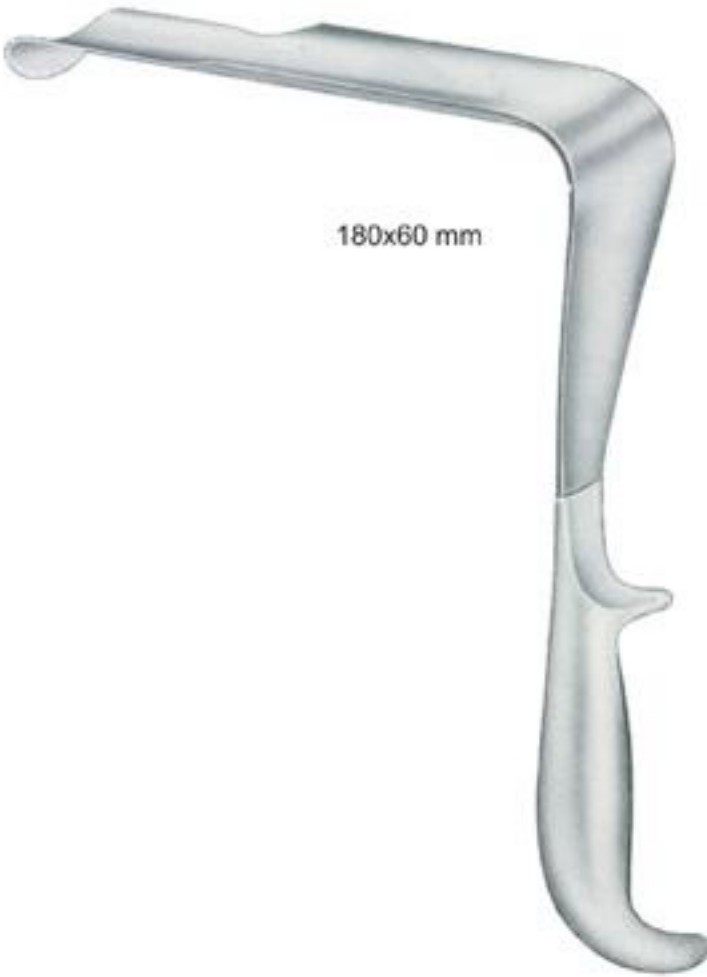

180x60 mm

St. Marks
11-0404-32
32.5cm/12¾"

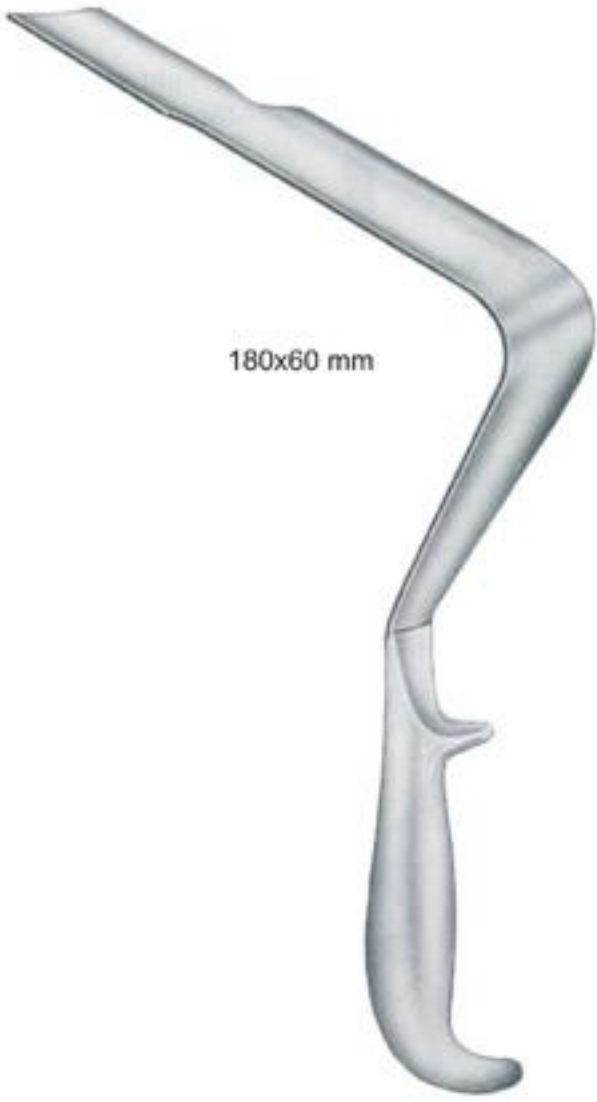

180x60 mm

St. Marks
11-0404-33
33cm/13"



11-0408-01
70x40 mm
11-0408-02
70x50 mm
11-0408-03
70x65 mm

Morris
21cm/8¼"



11-0412-01
32x50 mm/38x50mm
11-0412-02
45x50 mm/50x50mm
11-0412-03
65x50 mm/38x50mm

Morris
24cm/9½"

Meniscus Retractors

38x9 mm



11-0416-21
21cm/8¼"



40x5 mm

Blount
11-0420-18
18cm/7"



11-0424-01
15x15 mm

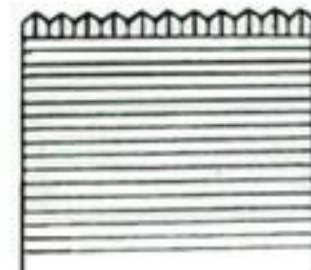

11-0424-02
15x23 mm

Crawford
19cm/7½"



Green
11-0428-22
22cm/8½"



11-0432-01



14x17 mm
21.5cm/8½"

11-0434-01

11-0432-02



20x22 mm
22cm/8¾"

11-0434-02

11-0432-03



26x30 mm
23.5cm/9¼"

11-0434-03



Middeldorpf

Middeldorpf



Middeldorpf
25.5cm/10"

- 11-0438-01
45x45 mm
- 11-0438-02
45x50 mm
- 11-0438-03
55x70 mm



Richardson
26cm/10 1/4"



11-0446-01
28x20 mm

11-0446-02
36x28 mm

11-0446-03
44x38 mm

11-0446-04
52x22 mm



49x38 mm
28x20 mm

Fig. 1 ▶

◀ Fig. 2

36x28 mm
63x49 mm

Richardson-Eastman

Set 11-0450-00

Fig. 1
26cm/10 1/4" 11-0450-01

Fig. 2
28cm/11" 11-0450-02



Kelly
26cm/10 1/4"

- 11-0454-01
40x50 mm
- 11-0454-02
50x65 mm
- 11-0454-03
65x75 mm
- 11-0454-04
75x90 mm

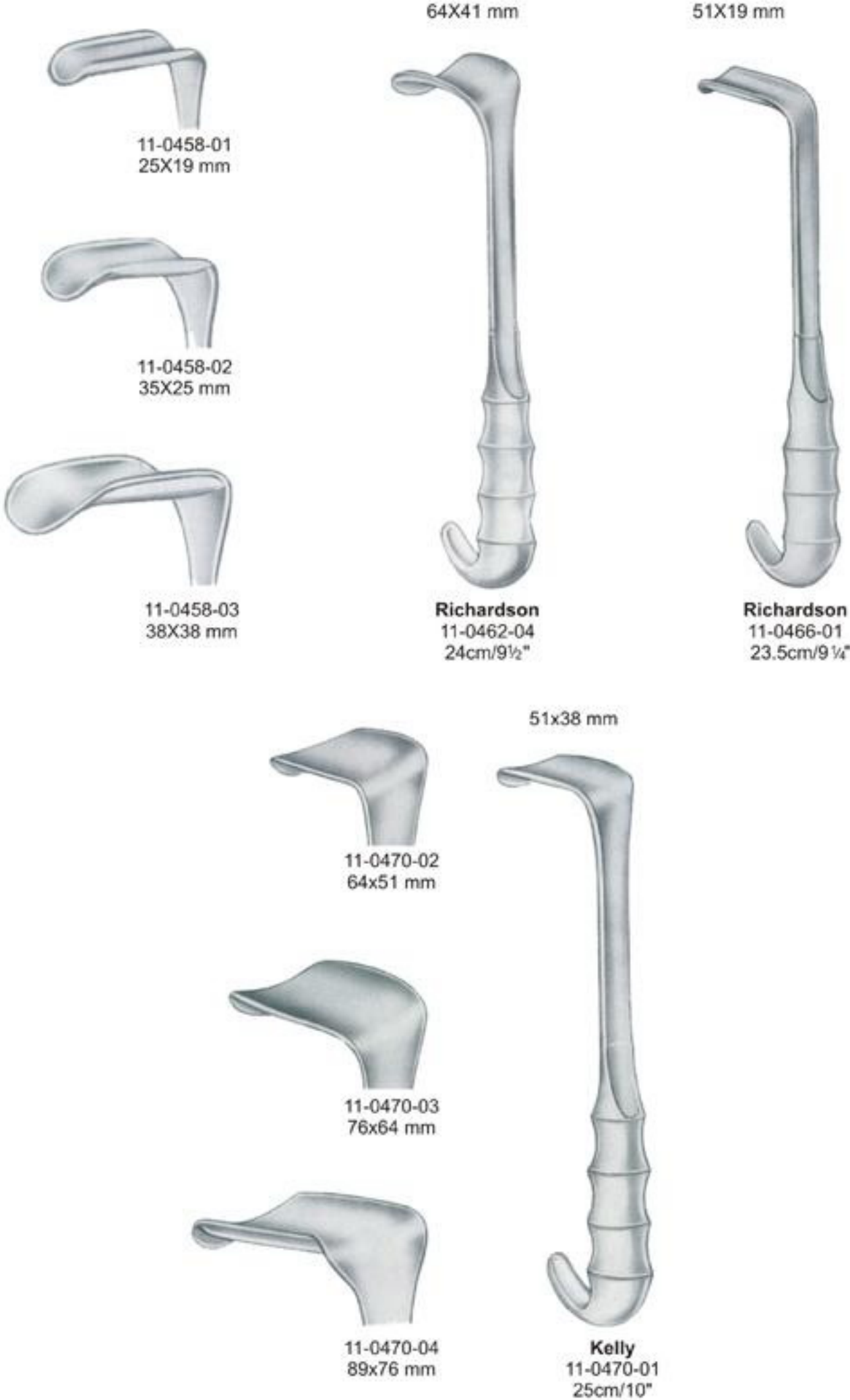



11-0474-01
40x40 mm
11-0474-02
45x40 mm
11-0474-03
45x50 mm
11-0474-04
45x60 mm
11-0474-05
45x75 mm
11-0474-06
65x85 mm

Fritsch
24cm/9½"

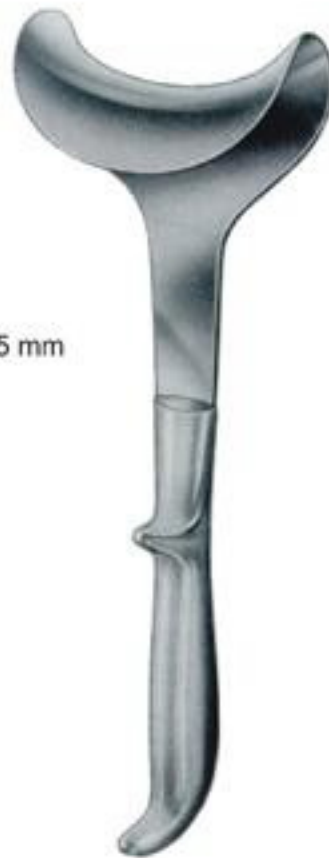

50x85 mm

Doyen
11-0478-25
25cm/10"



11-0482-01
15x90 mm
11-0482-02
20x90 mm
11-0482-03
30x90 mm
11-0482-04
35x110 mm
11-0482-05
40x110 mm
11-0482-06
55x120 mm

Doyen-Stille
24cm/9½"



70x25 mm

Kocher
11-0486-22
22.5cm/9"



11-0490-01
80x45 mm
11-0490-02
80x55 mm
11-0490-03
80x65 mm

Kocher
25cm/10"



64x60 mm

Tuffier
11-0494-23
23cm/9"

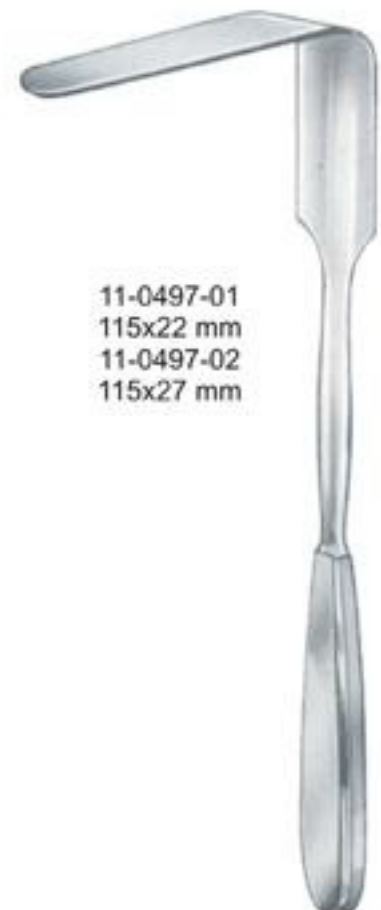

11-0497-01
115x22 mm
11-0497-02
115x27 mm

Simon
28cm/11"



95x20 mm

Tuebingen
11-0499-28
28cm/11"



105x27 mm

Martin
11-0502-26
26cm/10¼"

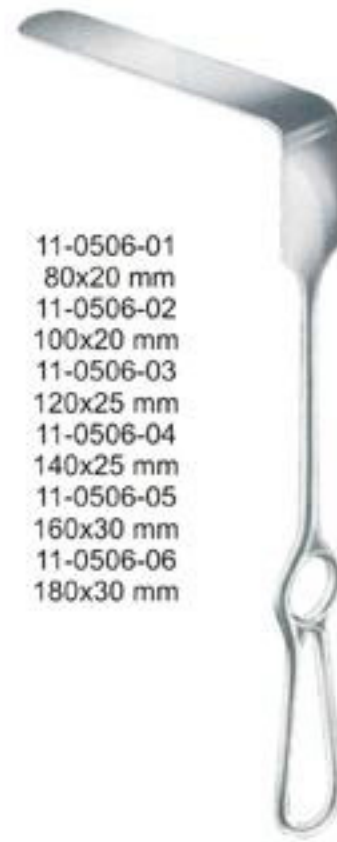

11-0506-01
80x20 mm
11-0506-02
100x20 mm
11-0506-03
120x25 mm
11-0506-04
140x25 mm
11-0506-05
160x30 mm
11-0506-06
180x30 mm

Brunner
25cm/10"



11-0510-01
80x20 mm
11-0510-02
100x20 mm
11-0510-03
120x25 mm
11-0510-04
140x25 mm
11-0510-05
160x30 mm
11-0510-06
180x30 mm

Brunner
25cm/10"



11-0514-01
95x35 mm
11-0514-02
120x50 mm
11-0514-03
155x50 mm

Mikulicz
26cm/10¼"



90x50 mm

Mikulicz
11-0516-26
26cm/10¼"



11-0520-01
160x38 mm
11-0520-02
160x57 mm
11-0520-03
190x38 mm
11-0520-04
190x57 mm

Kelly
27cm/10½"



Polloson
11-0524-27
27cm/10½"



Polloson
11-0526-27
27cm/10½"



11-0530-03
115x65 mm

11-0530-02
108x43 mm

11-0530-01
82x22 mm

Coryllos
23.0cm/9"



11-0534-25
125x37 mm

Sauerbruch
25cm/10"





Meyerding

11-0550-01
50x16 mm 20cm/8"
11-0550-02
75x25 mm 22cm/8¾"
11-0550-03
90x50 mm 24cm/9½"



Zenker

11-0554-01 25cm/10" 35x08 mm
11-0554-02 26cm/10¼" 60x12 mm
11-0554-03 27.5cm/10¾" 75x12 mm

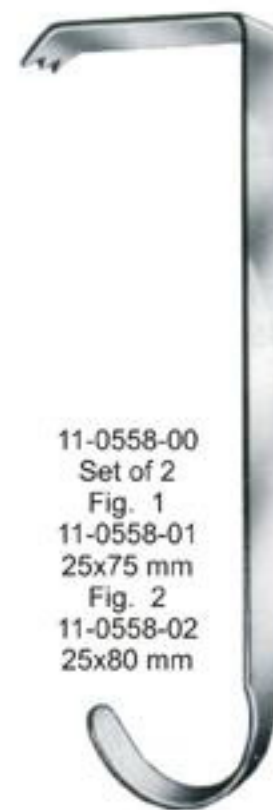

Hibbs
24cm/9½"

11-0558-00
Set of 2
Fig. 1
11-0558-01
25x75 mm
Fig. 2
11-0558-02
25x80 mm



11-0562-01
45x25 mm
11-0562-02
73x28 mm
11-0562-03
82x28 mm

Heaney
27cm/10½"

46 mm



Kuemmel
11-0564-33
33cm/13"



120x47 mm

rigid

Koerte
11-0568-28
28cm/11"



Kader
 11-0572-01 20mm
 11-0572-02 30mm
 11-0572-03 40mm
 27cm/10½"



11-0576-01
 25.5cm/10"
 45 mm
 11-0576-02
 27.5cm/10¾"
 60 mm

Leriche

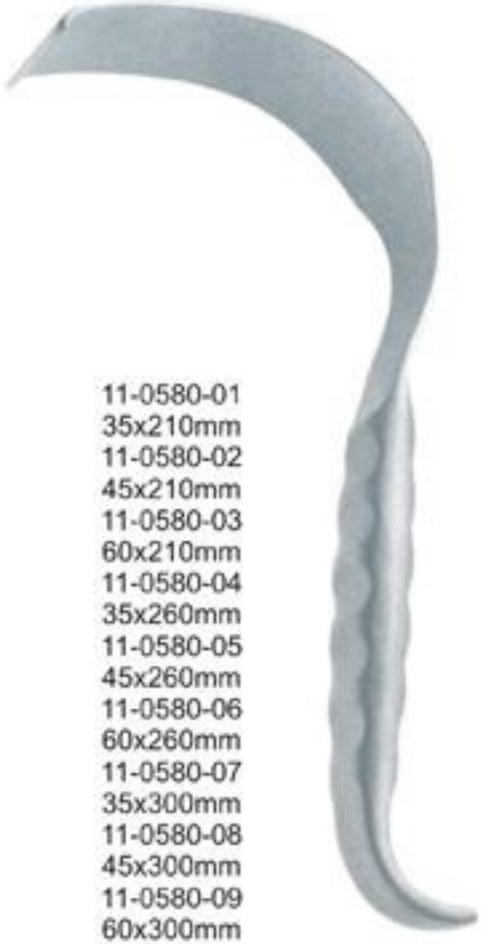

11-0580-01
 35x210mm
 11-0580-02
 45x210mm
 11-0580-03
 60x210mm
 11-0580-04
 35x260mm
 11-0580-05
 45x260mm
 11-0580-06
 60x260mm
 11-0580-07
 35x300mm
 11-0580-08
 45x300mm
 11-0580-09
 60x300mm



Malleable

11-0583-01	20 mm
11-0583-02	25 mm
11-0583-03	30 mm
11-0583-04	35 mm
11-0583-05	40 mm
11-0583-06	45 mm
11-0583-07	50 mm
11-0583-08	64 mm
11-0583-09	76 mm
11-0583-10	102 mm
	33cm/13"

Malleable



Tuffier
 11-0585-20
 20 cm/8"
 17x25 mm

Malleable

11-0587-01
 200x6 mm
 11-0587-02
 200x8 mm
 11-0587-03
 200x10 mm
 11-0587-04
 200x12 mm
 11-0587-05
 200x17 mm
 11-0587-06
 200x20 mm
 11-0587-07
 200x25 mm
 11-0587-08
 250x25 mm



20cm/8"

Malleable

11-0589-01
 280x25/30 mm
 11-0589-02
 300x37/45 mm
 11-0589-03
 300x40/50 mm



Haberer



Reverdin
 11-0593-28
 28 cm/11"



Davidson
16cm/6¼"



75x50 mm
75x90 mm

11-0598-01
11-0598-02



Cooley
11-0602-01
21.5cm/8½"



Cooley
11-0602-02
21.5cm/8½"



Cooley
11-0602-03
23cm/9"



Ross
27cm/10½"

- Fig. 1 11-0606-01 13x13 mm
- Fig. 2 11-0606-02 14x12 mm
- Fig. 3 11-0606-03 18x18 mm
- Fig. 4 11-0606-04 20x20 mm
- Fig. 5 11-0606-05 22x18 mm
- Fig. 6 11-0606-06 26x24 mm

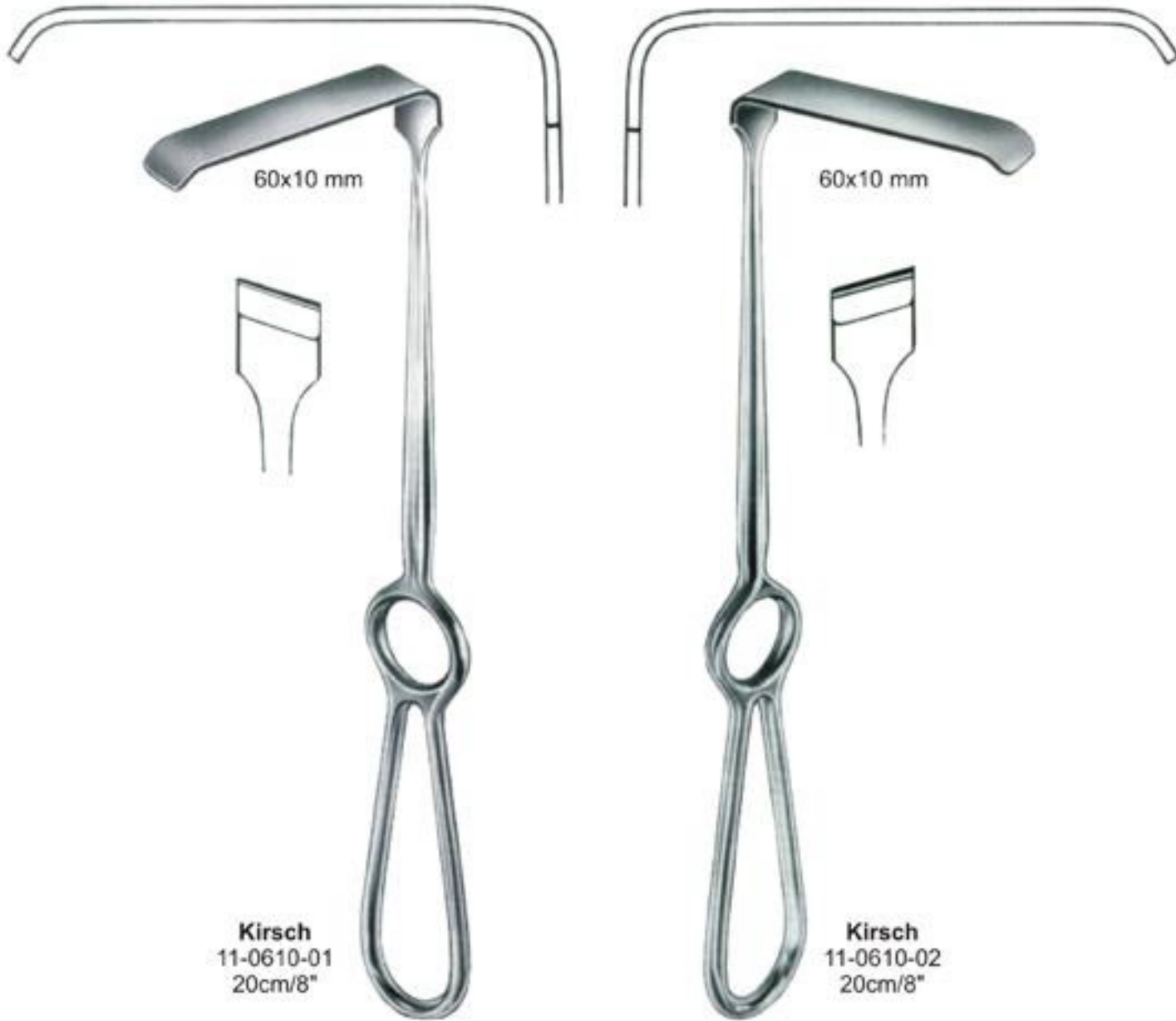



Spina-Nasalis
11-0622-01
22 cm/8³/₄"

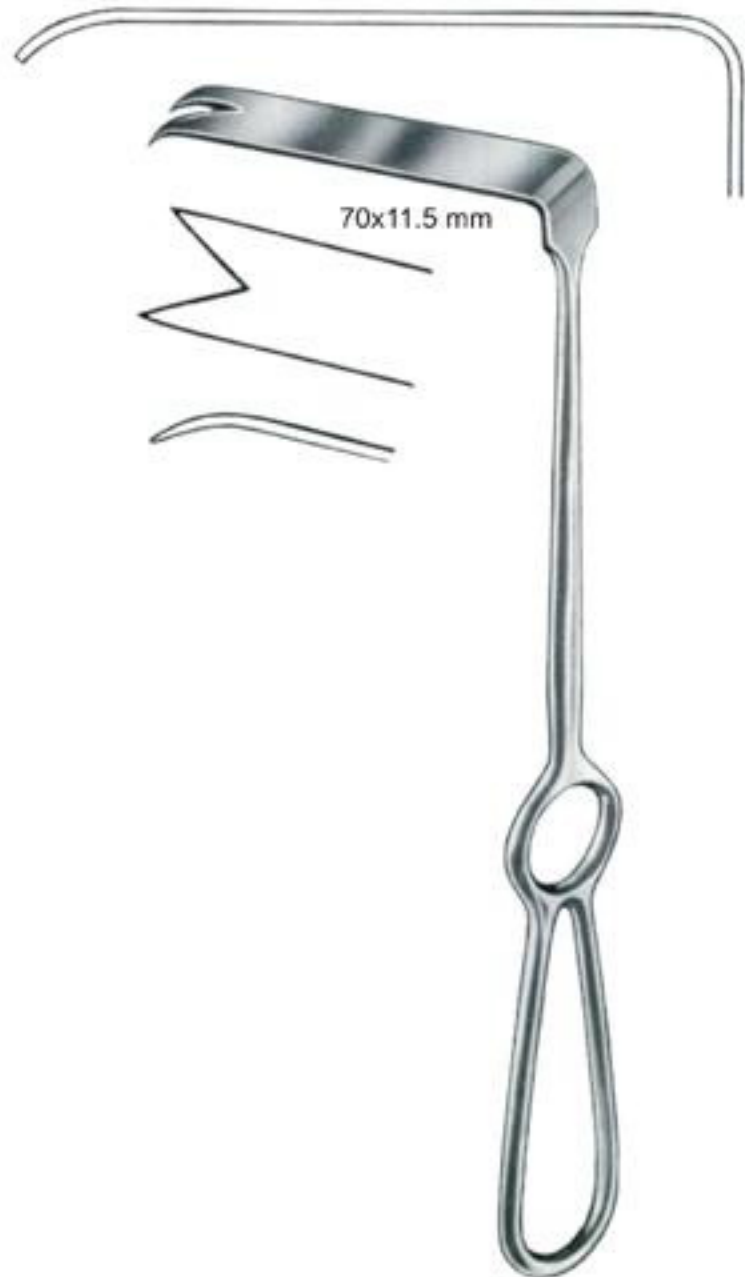

Ramus
11-0622-02
22 cm/8³/₄"



Obwegeser
11-0626-15
15.5 cm/6"



Obwegeser
11-0630-16
16 cm/6¹/₄"



11-0633-10 10 mm
 11-0633-20 20 mm
 19cm/7½"



Dingman
 11-0637-17
 17.5cm/7"



Soeresen-Hein
 11-0640-17
 17.5cm/7"



Dingman
 11-0644-21
 21cm/8¼"



11-0648-18
 18.5cm/7¼"



Tessier
 11-0653-01
 15cm/6"

Tessier
 11-0653-02
 15cm/6"



Dingman
 11-0658-00



Obwegeser-Freer
 11-0662-21
 21cm/8 1/4"



Obwegeser-Freer
 11-0666-20
 20.5cm/8"



Obwegeser
 11-0670-17
 17.5cm/7"

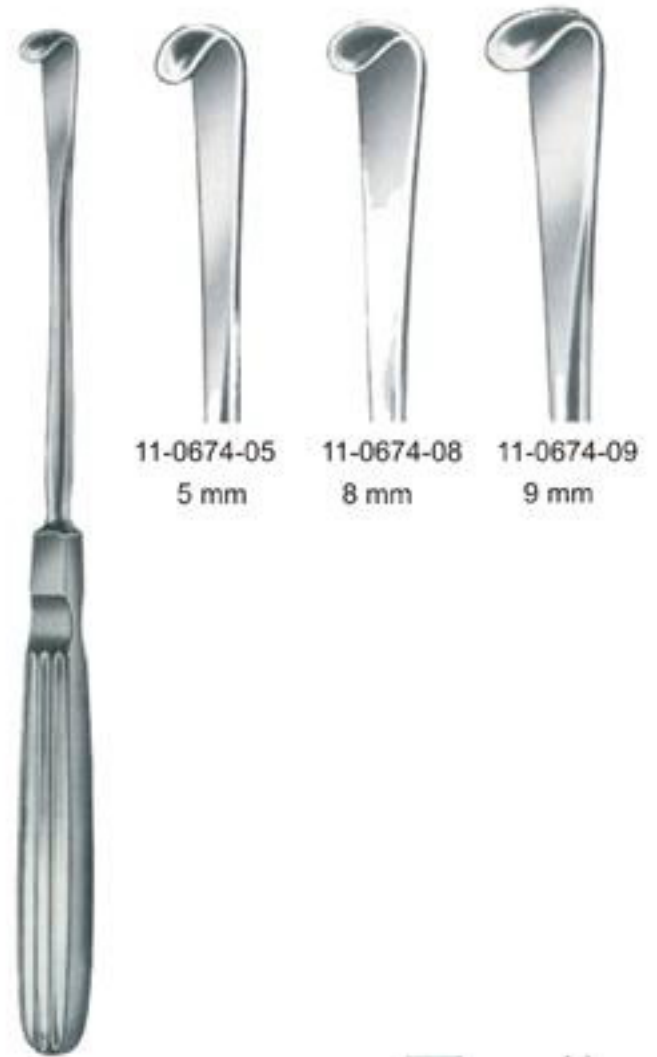

11-0674-05
 5 mm

11-0674-08
 8 mm

11-0674-09
 9 mm



Obwegeser
 11-0678-06
 17.5cm/7"



11-0678-06
 6 mm



11-0678-07
 7 mm



11-0678-09
 9 mm



11-0678-11
 11 mm



Dingman
 11-0682-18
 18cm/7"



Obwegeser
 11-0686-23
 23.5cm/9 1/4"
 10 mm



Tessier
20.5cm/8"



11-0690-10
10 mm



11-0691-10
10 mm



Obwegeser
11-0694-01
18.5cm/7 1/4"



Obwegeser
11-0694-02
18.5cm/7 1/4"



11-0698-07
7 mm
21.5cm/8 1/2"



11-0698-10
10 mm
21.5cm/8 1/2"



11-0702-02
2.5 mm



11-0702-04
4 mm



Bowdler-Henry's
11-0706-16
16.5cm/6 1/2"



Gillies
11-0710-21
21cm/8 1/4"



Gillies
11-0712-21
21cm/8 1/4"



Sanders-Brown
11-0716-30
30cm/12"



Sanders-Brown
11-0718-29
29cm/11½"



Obwegeser
11-0722-14
14cm/5½"



Obwegeser
11-0724-23
23cm/9"



Obwegeser
11-0726-18
18cm/7"



Kelsey-Fry
11-0730-16
15cm/6"



Kelsey-Fry
11-0732-18
18cm/7"



Mershon
11-0736-14
14.5cm/5½"

General Instruments

Retractors

11



Bose



Finsen



Finsen

Sharp

Blunt

Sharp

cm	in				
5	2		11-0743-05	11-0744-05	11-0747-05
7	2 3/4"	11-0740-07	11-0743-07	11-0744-07	11-0748-07 Blunt



Allport
11-0754-09
9.5cm/3 3/4"



Alm

Sharp

Blunt

cm	in		cm	in		
8.5	3 1/2"	11-0750-08	7	2 3/4"	11-0757-07	11-0758-07
11.5	4 1/2"	11-0750-11	10	4	11-0757-10	11-0758-10



Holzheimer
Sharp 11-0761-10 10 cm/4" Blunt 11-0762-10



Jansen
Sharp 11-0765-10 10.5 cm/4 1/4" blunt 11-0766-10



Jansen-Deep
Sharp 11-0769-10 10.5 cm/4 1/4" blunt 11-0770-10



Belucci
11-0773-11 11.5cm/4 1/2"
11-0773-13 13cm/5"



Belucci
11-0774-11
11-0774-13



Plester
Sharp 11-0777-13 13 cm/5" blunt 11-0778-13



Weitlaner

Sharp

11-0781-10

Blunt

11-0782-10

10.5 cm/4¼"

13 cm/5"

16.5 cm/6½"



Weitlaner

Sharp

11-0785-13

Blunt

11-0786-13

11-0785-16

11-0786-16



Weitlaner-Wullstein

Sharp

11-0789-13

Blunt

11-0790-13

11-0789-16

11-0790-16



Mollison

11-0793-15

15 cm/6"



Tuebinger-Modell

11-0796-16

16 cm/6¼"



Henner(Lempert)

11-0800-12

12 cm/4½"

Complete with 2 pairs of blades and centre blade

Complete with 3 Central blades



Central blades, only



Henley

Sharp 11-0803-16	16.5 cm/6½"	Blunt 11-0804-16
---------------------	-------------	---------------------

11-0805-19 16x19 mm	11-0805-25 16x25 mm	11-0805-32 16x32 mm
------------------------	------------------------	------------------------



Weitlaner-Baby

13 cm/5"	11-0808-13
16 cm/6¼"	



Milligan

Sharp 11-0811-13	Blunt 11-0812-13
---------------------	---------------------



Cone (Adson-Baby)

Sharp 11-0815-13	Blunt 11-0816-13
11-0815-16	11-0816-16



Weitlaner

	Sharp	Blunt	Sharp	Blunt
20 cm/8"	11-0819-20	11-0820-20	11-0823-25	11-0824-25
25 cm/10"	11-0819-25	11-0820-25		



3x4 Teeth



5x6 Teeth



Adson



Anderson-Adson



Cone

	Sharp	Blunt	Sharp	Blunt	Sharp	Blunt
20 cm/8"	11-0827-20	11-0828-20	11-0831-20	11-0832-20	11-0835-20	11-0836-20
26 cm/10 1/4"	11-0827-26	11-0828-26			11-0835-26	11-0836-26



Travers
11-0840-21
21 cm/8¼"



Beckmann-Adson
31 cm/12¼"



3x4 Teeth

Adson
27 cm/10½"

Jaws Depth

	Sharp	Blunt	Sharp	Blunt
25 mm	11-0843-01	11-0844-01	11-0847-27	11-0848-27
44 mm	11-0843-02	11-0844-02		

5x6 Teeth



Adson

Sharp 11-0851-27 27cm/10½"
Blunt 11-0852-27



Beckmann

11-0856-01 10mm 14cm/5½"
11-0856-02 12mm 17cm/6¾"
11-0856-03 15mm 21cm/8¼"

11-0856-04 20mm
11-0856-05 30 mm
11-0856-06 50mm
30 cm/12"



Beckmann

Sharp 11-0860-31 31cm/12¼"
Blunt 11-0861-31

Hemilaminectomy Retractor



11-0869-27
27cm/10½"



Beckmann-Eaton
11-0871-33
33 cm/13"

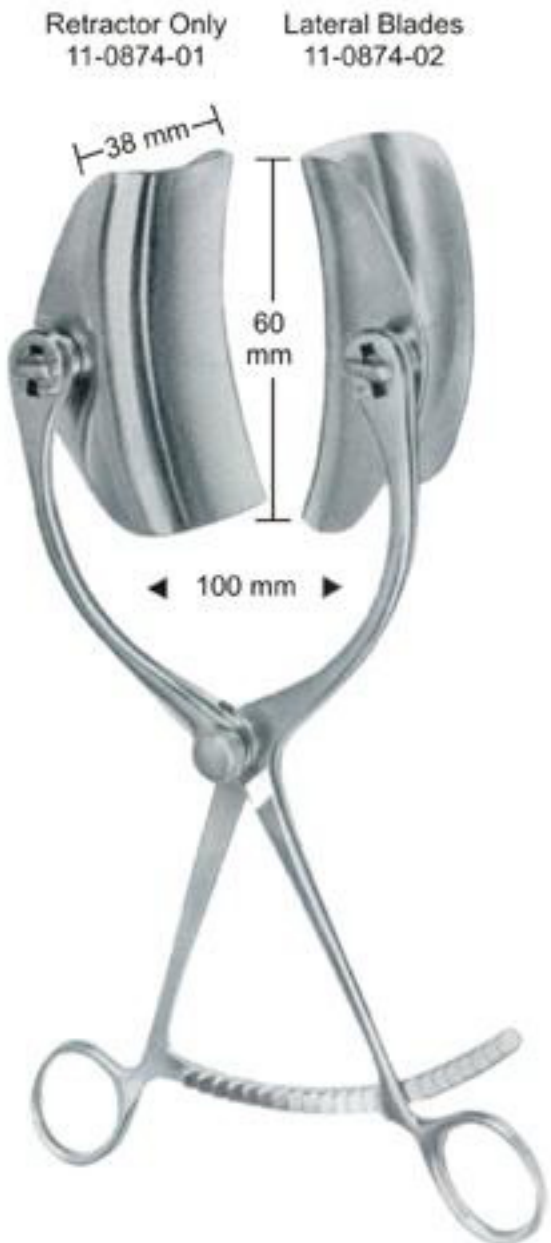

Retractor Only 11-0874-01
Lateral Blades 11-0874-02

Collin
11-0874-00
22cm/8¾"



with 2 pairs of blades

Baby-Collin
11-0878-00
18 cm/7"



11-0878-01



Collin
22 cm/8 3/4"

	Fig. 1 11-0882-00	Fig. 2 11-0884-00	Fig. 3 11-0886-00
Retractors Complete	11-0882-00	11-0884-00	11-0886-00
Retractors Only	11-0882-01	11-0884-01	11-0886-01
Lateral Blades	11-0882-02 38x60 mm	11-0884-02 38x80 mm	11-0886-02 38x100 mm
Central Blades	11-0882-03 55x55 mm		11-0886-03 55x75 mm

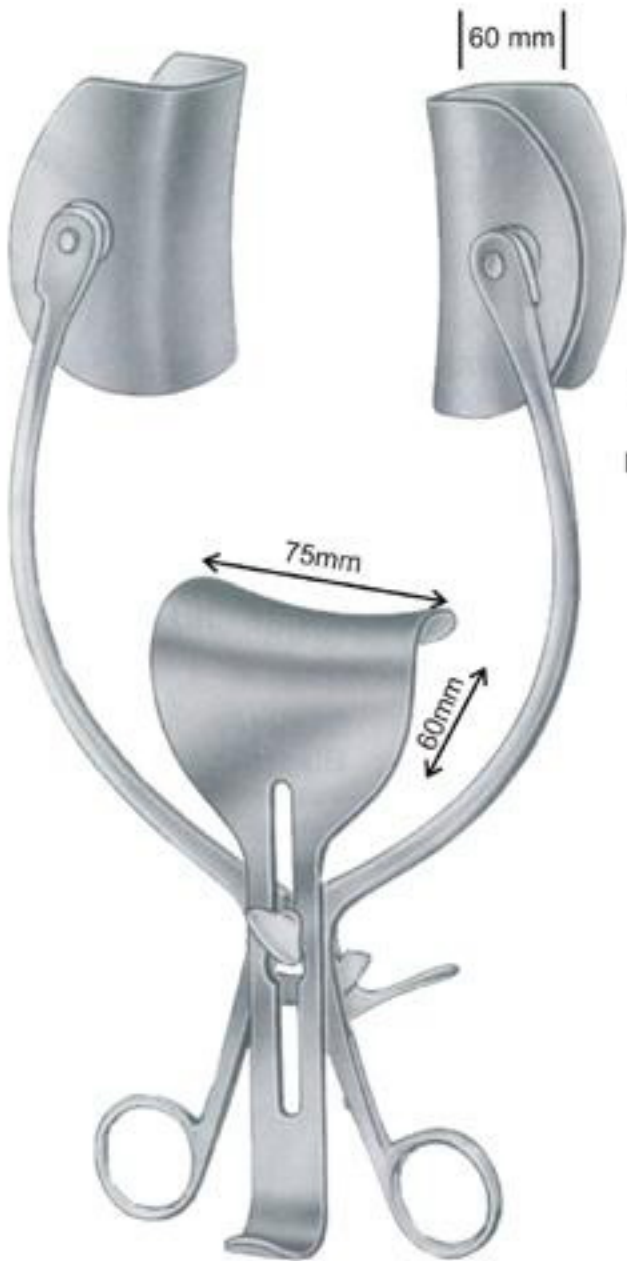

Collin
26 cm/10½"

Retractor Complete
11-0890-00
26cm/10½"
Lateral Blades
11-0890-01
60X80mm
Central Blades
11-0890-02
75X60mm
Retractor Only
11-0890-03



Mayo-Adams
11-0894-17
17cm/6¾"

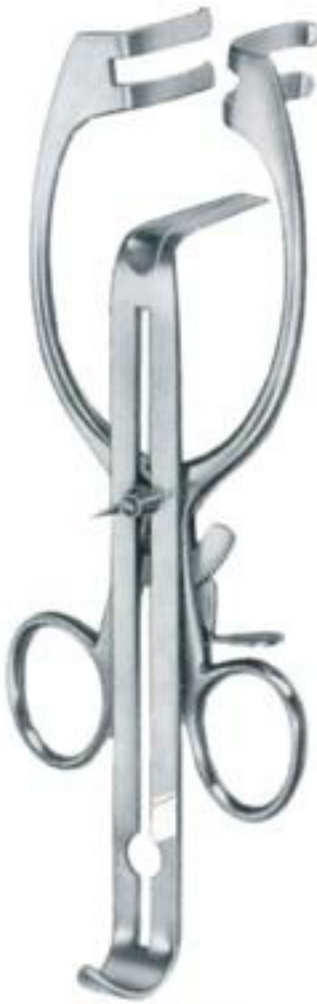

Mayo-Adams
11-0896-17
17cm/6¾"

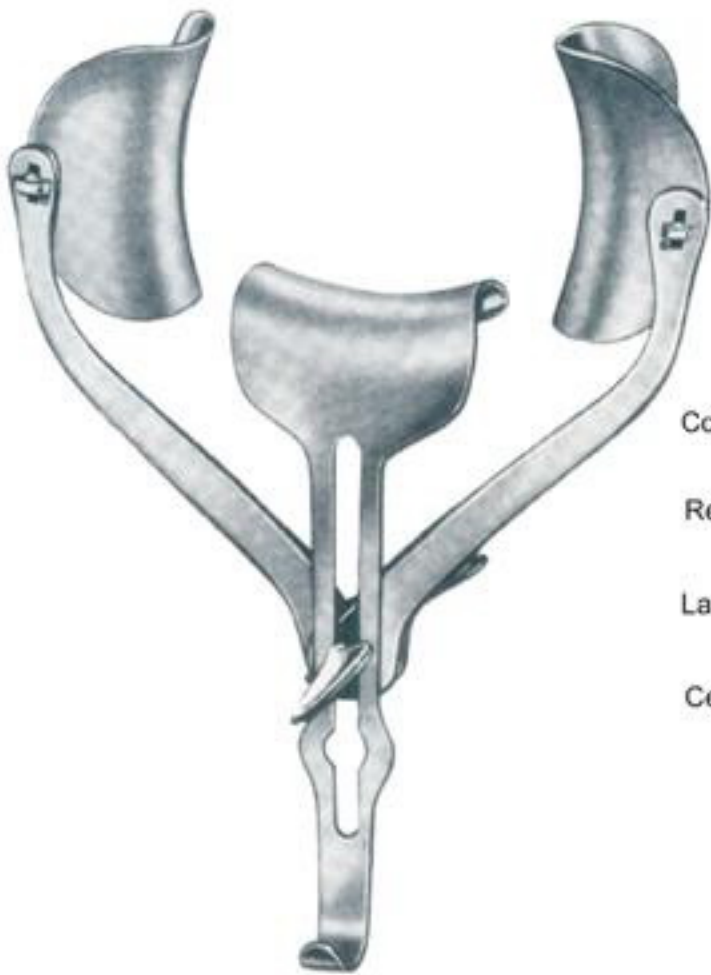

Ricard
 11-0900-00 28cm/11"
 11-0904-00 30cm/12"

	Fig. 1	Fig. 2
Complete	11-0900-00	11-0904-00
Retractors Only	11-0900-01	11-0904-01
Lateral Blades	11-0900-02 60x80 mm	11-0904-02 75x85 mm
Central Only	11-0900-03 55x70 mm	11-0904-03 80x90 mm

Vulval Retractor



Richter
 11-0908-16
 16.5 cm/6 1/2"



Gelpi
 11-0912-09 9 cm/3 1/2"
 11-0912-11 11 cm/4 1/2"
 11-0912-13 13 cm/5"
 11-0912-18 18 cm/7"



Gelpi
 11-0916-18
 18 cm/7"



Meyerding
 Fig. 1 11-0920-01
 Fig. 2 11-0920-02
 Fig. 3 11-0920-03
 Fig. 4 11-0920-04
 18 cm/7"

Blades

- Fig. 1 1 3/4"x1"
- Fig. 2 2 1/8"x1"
- Fig. 3 2 3/8"x1 3/4"
- Fig. 4 2 3/8"x1"



Markham-Meyerding

11-0923-18 18cm/7" 11-0924-18



Rigby

11-0928-19
19cm/7½"



De Bakey

11-0932-12 12cm/4¾"
11-0932-17 17cm/6¾"

◀ 10cm/4" ▶

40x30mm



Gosset
11-0936-00

◀ 140mm ▶

63x35mm

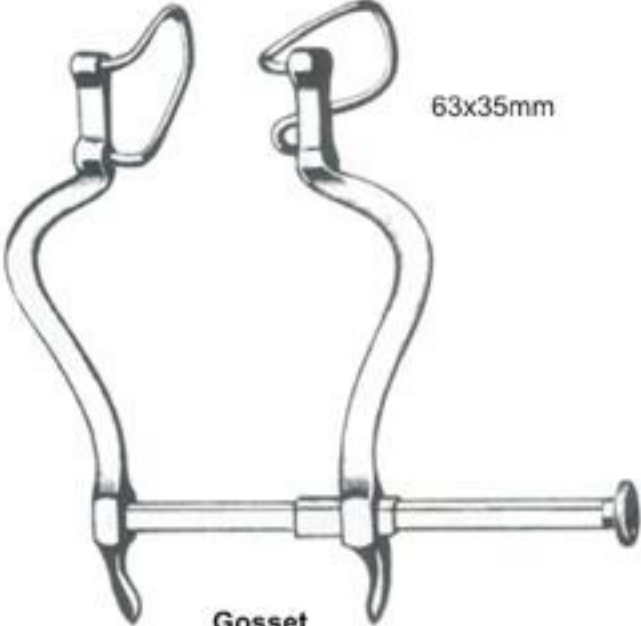

Gosset
11-0940-00

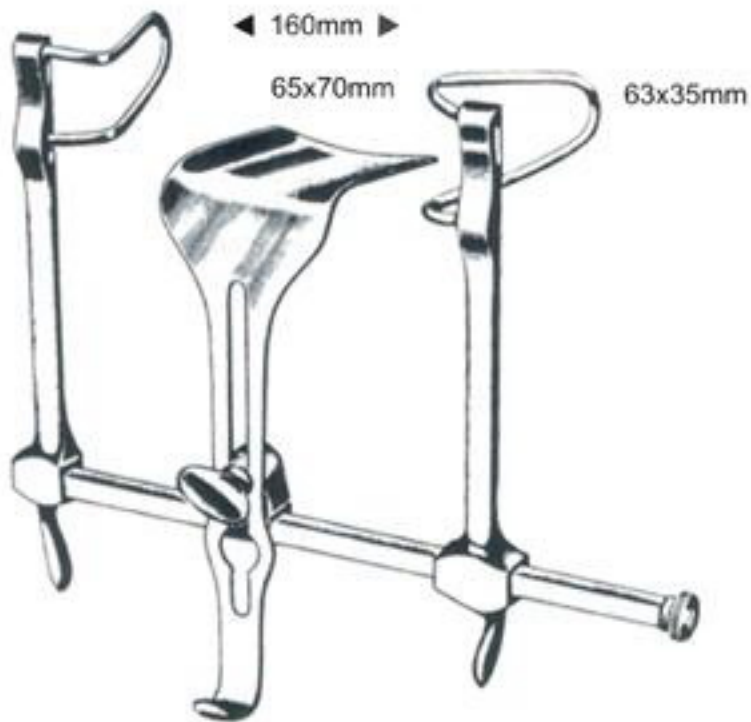

Gosset
11-0944-16



Hertzler
11-0948-00



Frazier
11-0952-00

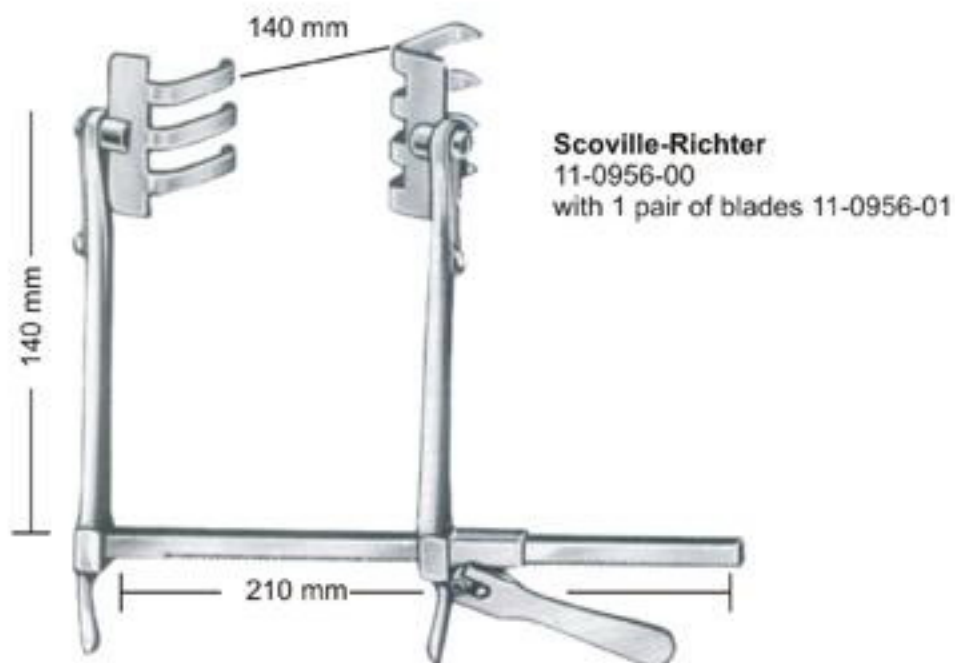

the blades are available by pairs

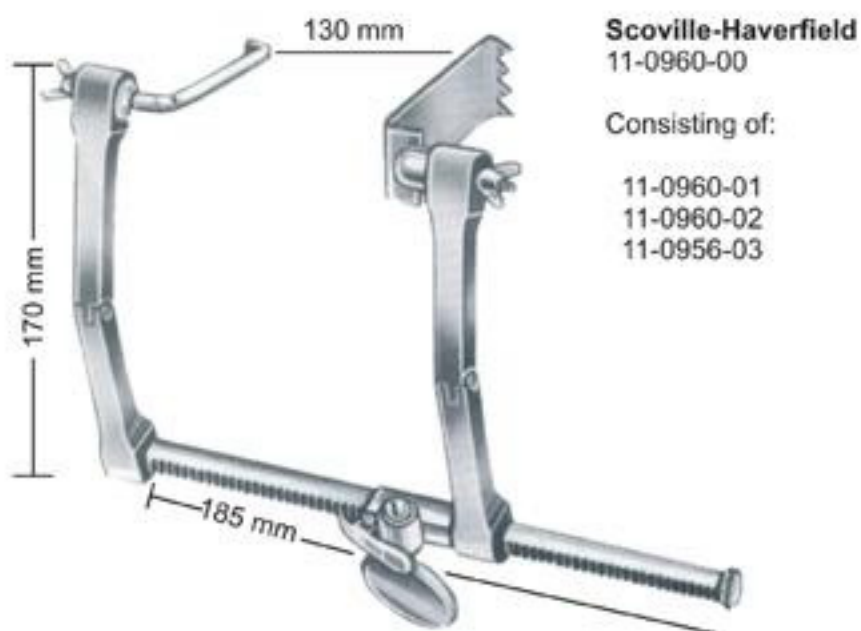
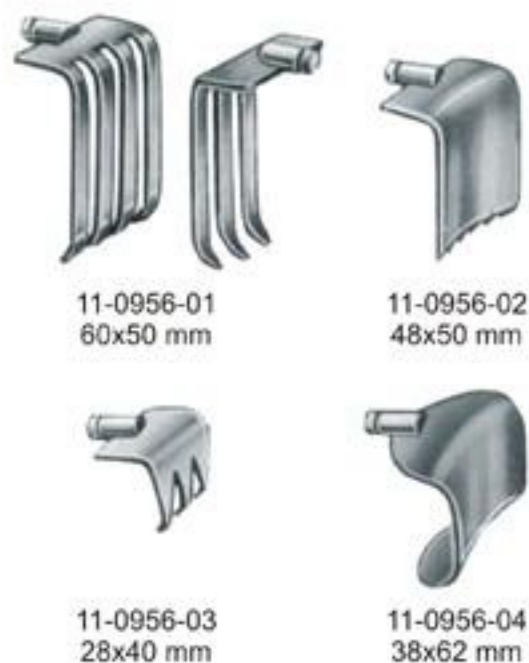

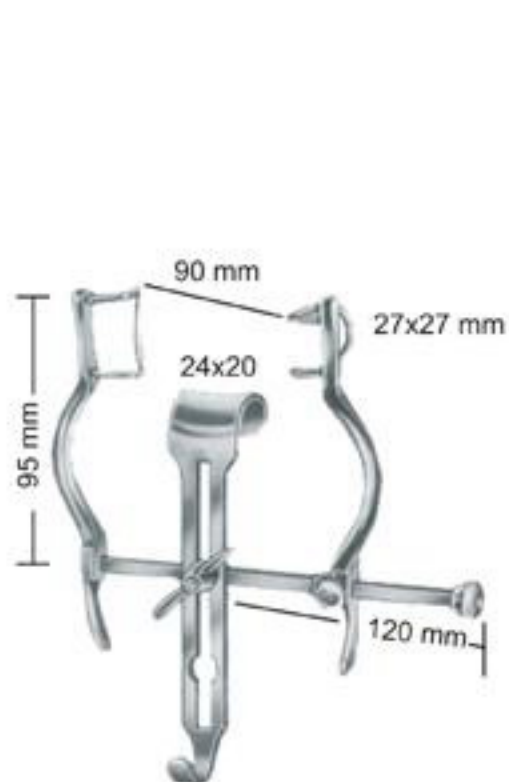

Baby-Balfour
Retractor complete 11-0968-00

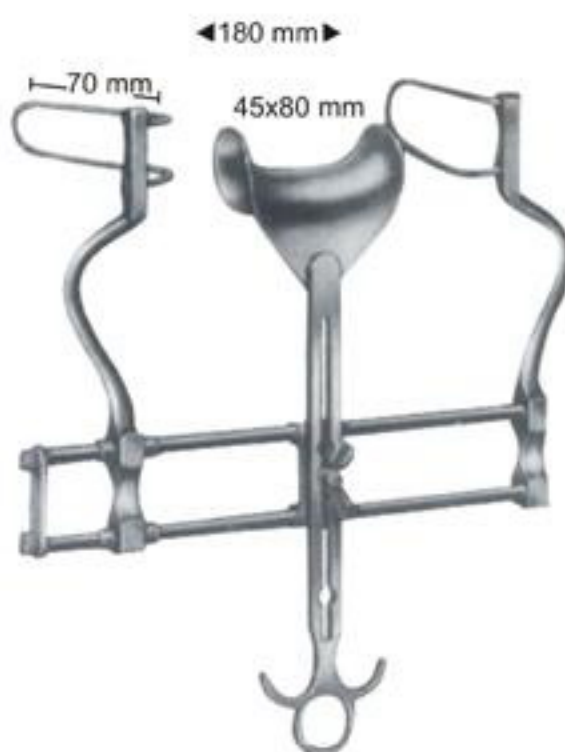

Balfour
11-0972-18

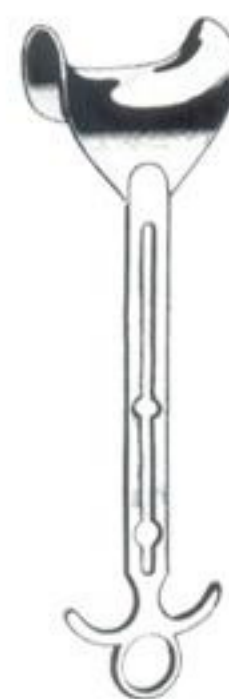

Balfour
11-0974-01 80x90mm

Retractor only 11-0968-01

11-0972-01

Center blade 11-0968-02
24x20mm

11-0972-02
45x80mm



Balfour

Retractor Complete
11-0976-18

Retractor Only
11-0976-01

Central Blade Only
11-0976-02
45x80mm

Solid blade

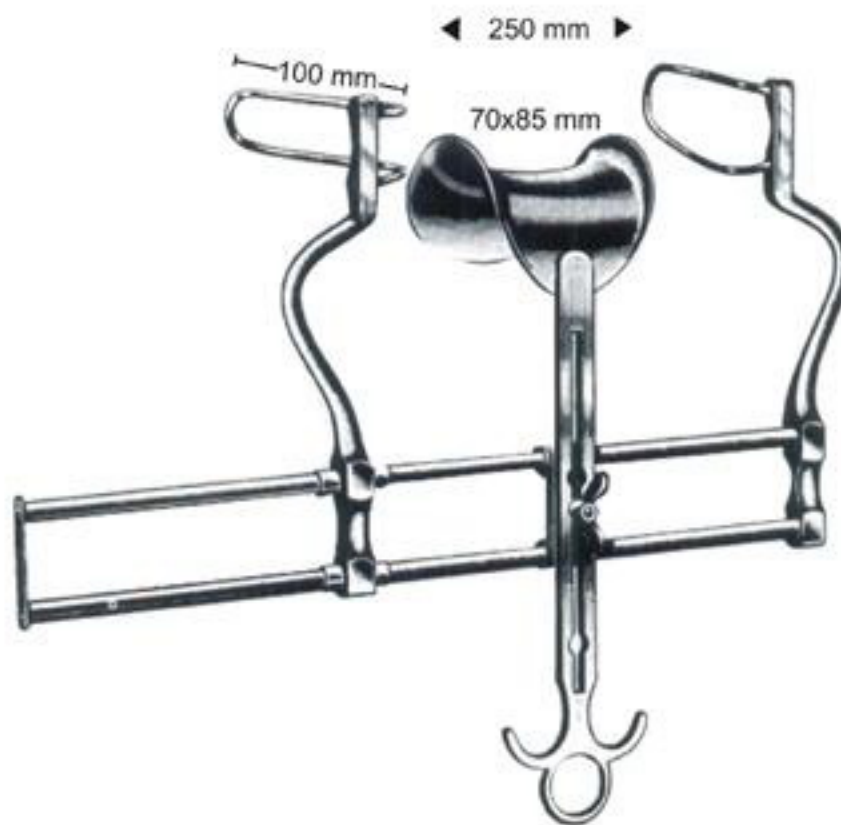

Balfour
11-0980-25

Retractor, Complete
11-0980-25

Retractor Only
11-0980-01

Central Blade Only
11-0980-02
70x85mm

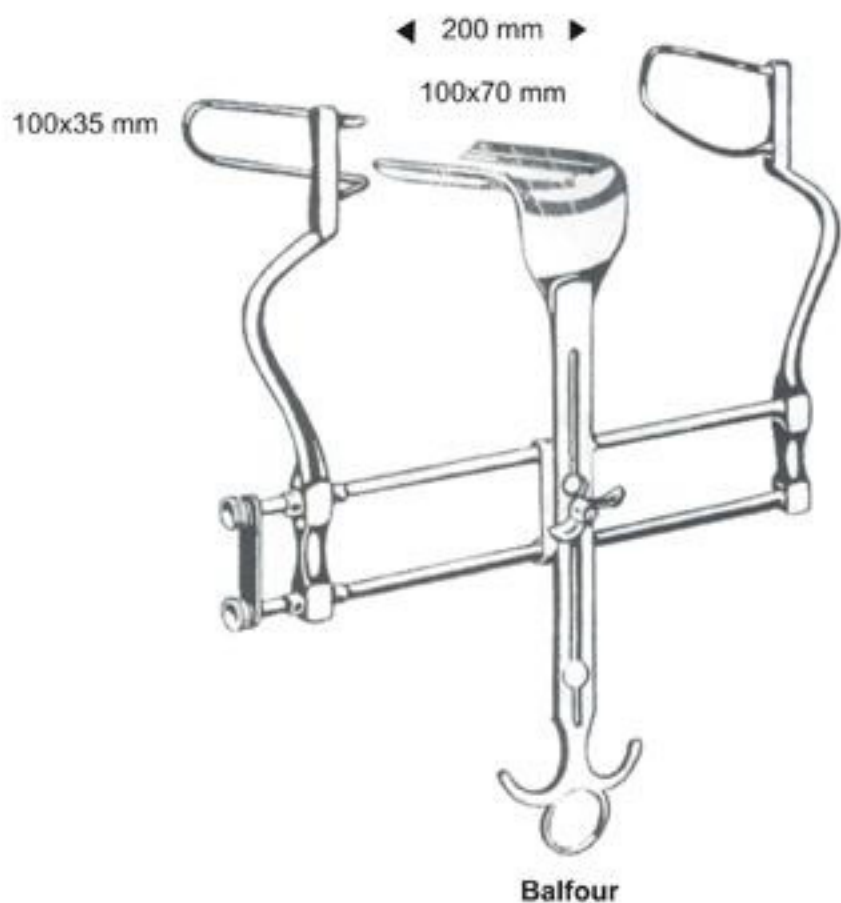

Retractor Complete
11-0984-20

Retractor Only
11-0984-01

Central Blade Only
11-0984-02
100x70mm



Balfour us-Type
11-0988-00
Complete



11-0988-01

Lateral blades, 6cm deep, per pair

11-0988-02

Lateral blades, 8cm deep, per pair

Center blade only
11-0988-03
40x68mm
11-0988-04
68x85mm

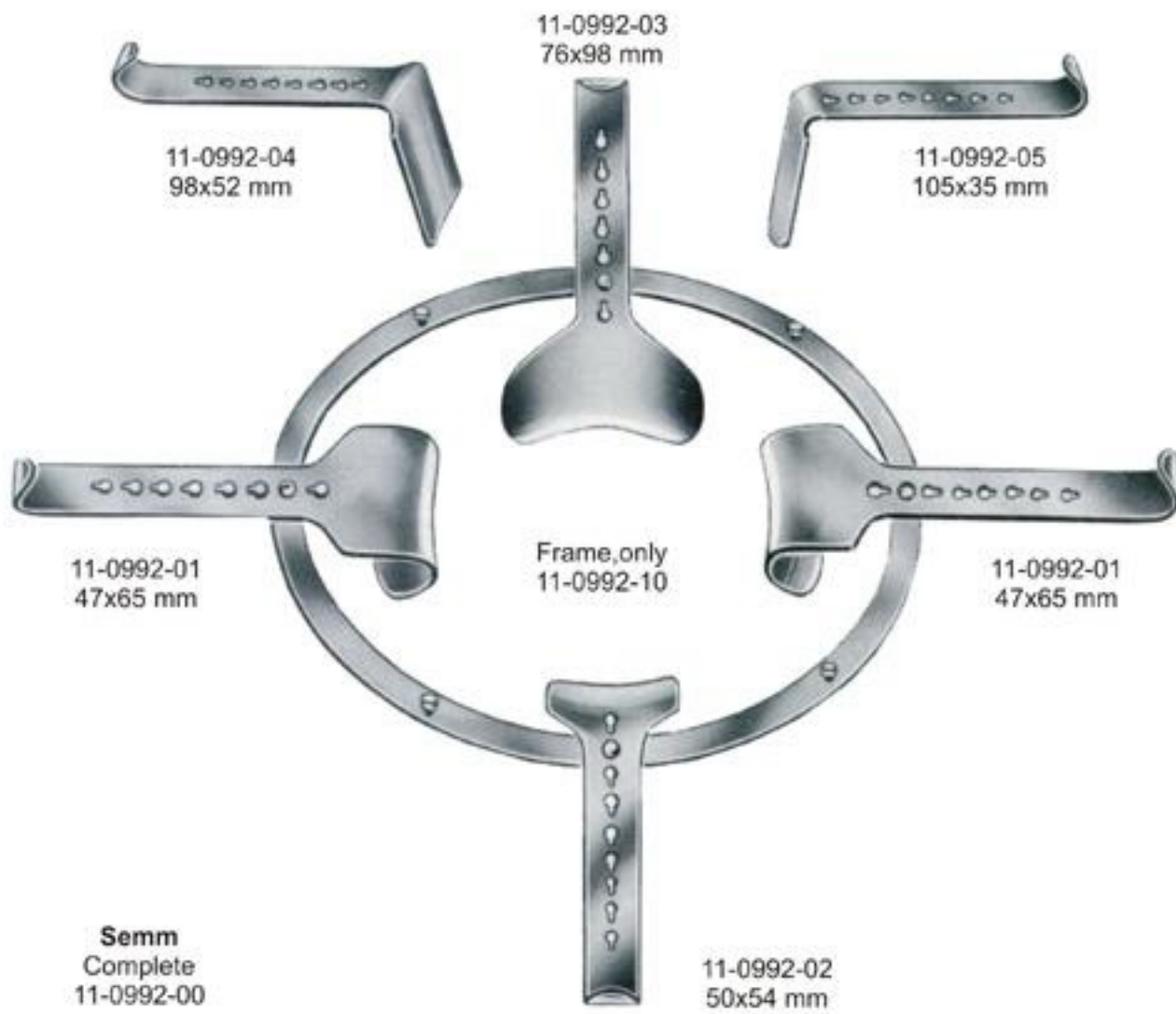

Kirschner
Complete
11-0996-00
1x 11-0996-10
2x 11-0996-01
2x 11-0996-02

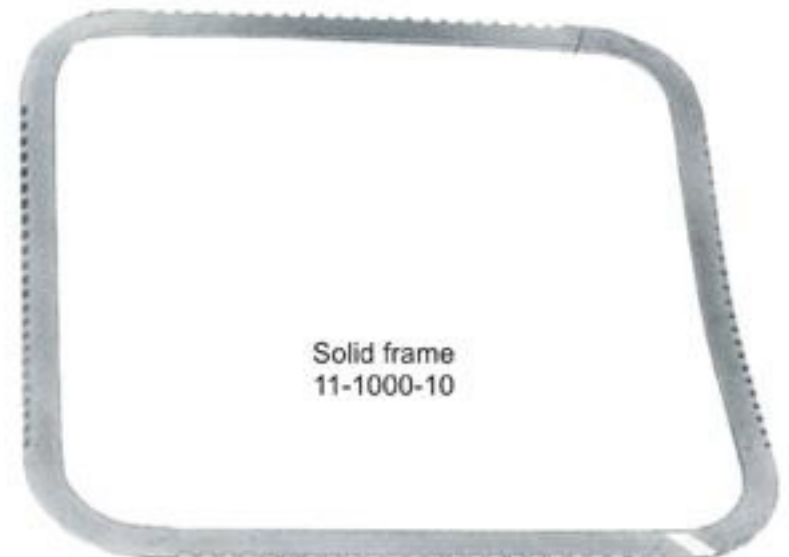

Kirschner
Complete
11-1000-00
1x 11-1000-10
2x 11-1000-01
2x 11-1000-02



Frame

11-1004-10 178x140 mm
11-1006-20 255x178 mm



Fig.1 11-1004-01 38x38 mm
Fig.2 11-1004-02 38x25 mm

Complete
11-1004-00
11-1006-00

Denis-Brown
Consisting of

1x 11-1004-10
1x 11-1006-20

2x 11-1004-01
2x 11-1006-01

2x 11-1004-02
2x 11-1006-02



110x70 mm

O'Sullivan-O'Connor
Complete
11-1010-00



11-1010-01
80x45 mm



11-1010-02
80x45 mm



11-1010-03
110x70 mm



Doyen

11-1014-01 48x90mm
11-1014-02 48x105mm
11-1014-03 48x120mm
11-1014-04 48x135 mm



Rochard

11-1018-01 40x80mm
11-1018-02 50x100mm
11-1018-03 55x120mm



Doyen-Rochard

11-1022-01 45x80mm
11-1022-02 50x100mm
11-1022-03 65x120mm

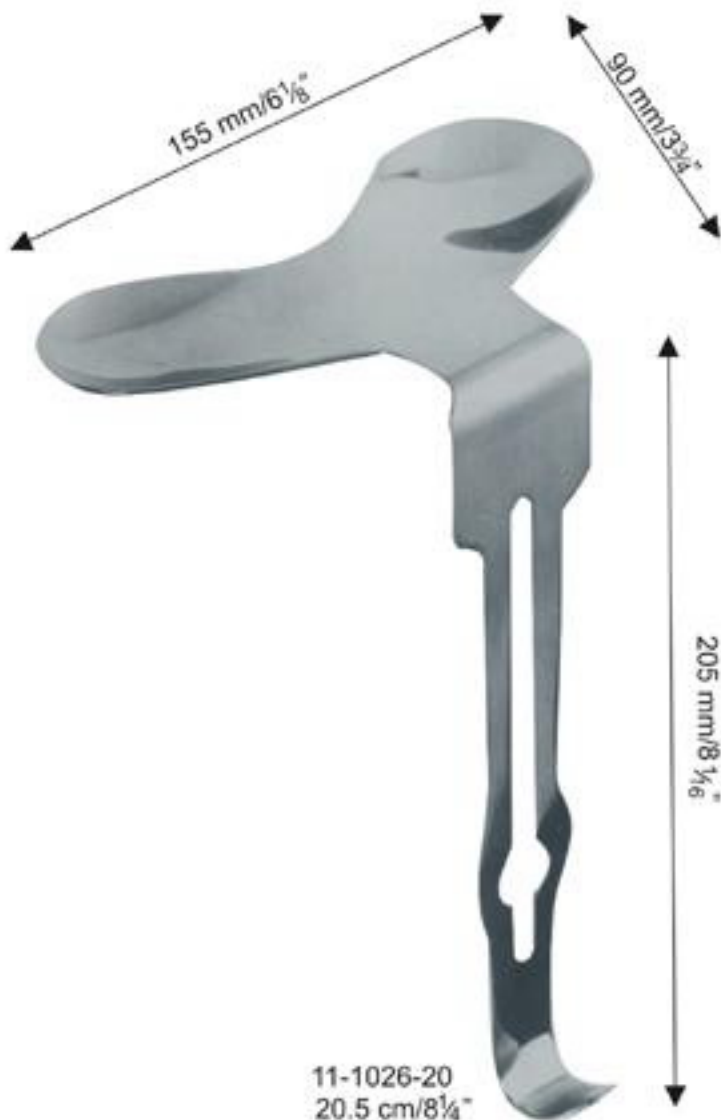

11-1026-20
20.5 cm / 8 1/4"



11-1030-19
19 cm / 7 1/2"



Goliger complete
11-1034-00
Retractor only
11-1034-01
Lateral blades
11-1034-02
5cm x 3cm
11-1034-03
9cm x 5cm
Central blade
11-1034-04
5cm x 9cm
11-1034-05
9cm x 9cm

Goliger

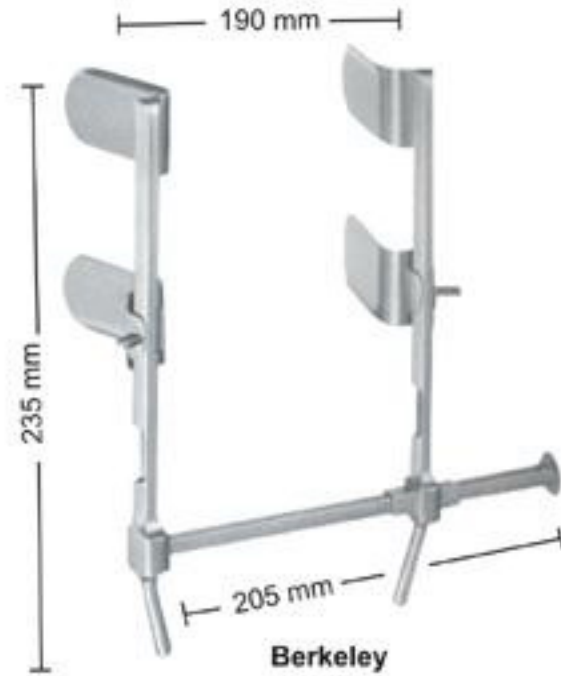

Berkeley complete
11-1038-00
Retractor only
11-1038-01
Lateral blades
11-1038-02
35mm x 60mm

Berkeley

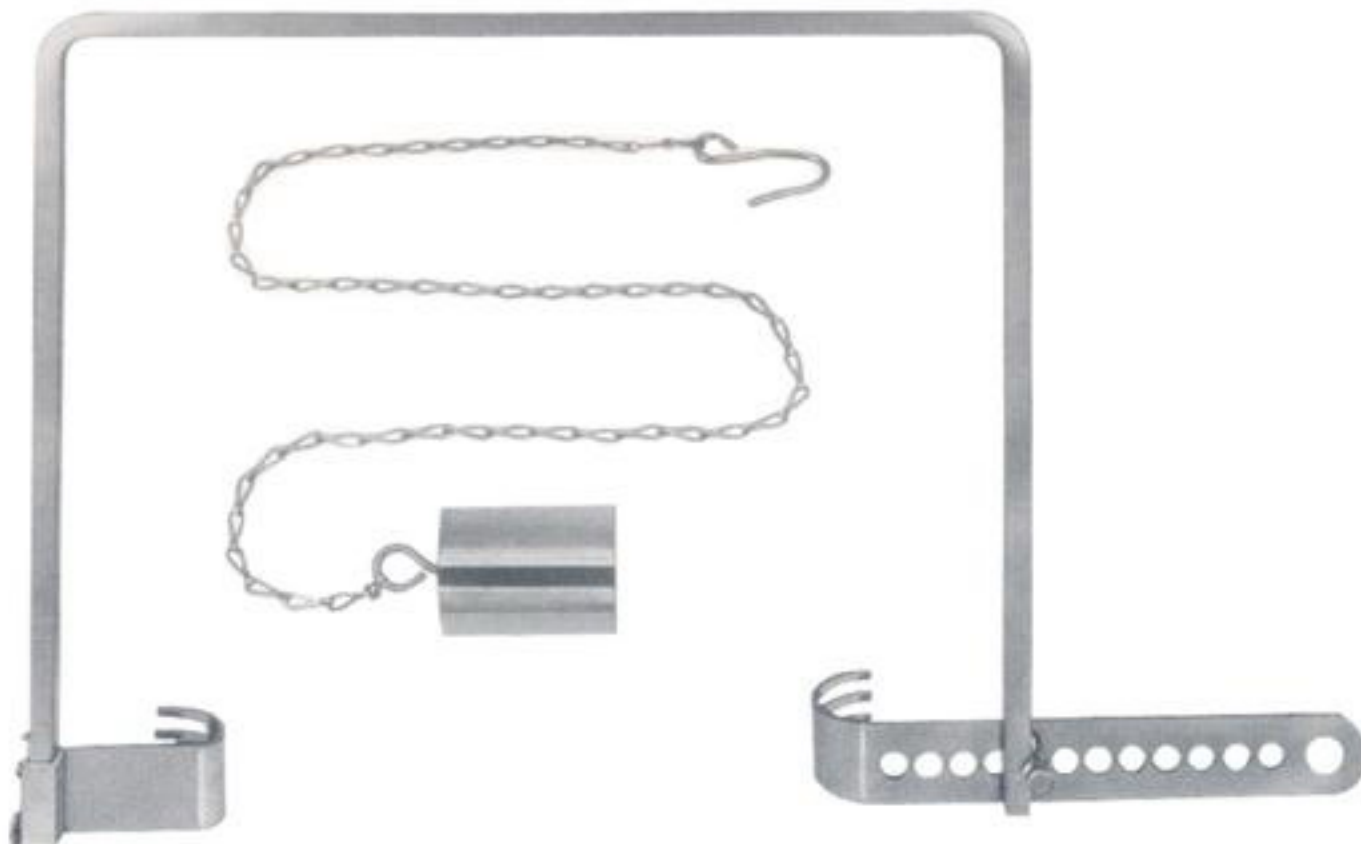

Charnley
11-1042-00

11-1046-01 38x60 mm
11-1046-02 45x80 mm



Foldable Frame
11-1046-10

Franz

11-1046-03 50x65 mm
11-1046-04 60x85 mm

Complete with 4 valves
11-1046-40

With
con

11-1046-10 1x
11-1046-01 2x
11-1046-03 2x

Complete with 8 valves
11-1046-80

With
con

11-1046-10 1x
11-1046-01 2x
11-1046-02 2x
11-1046-03 2x
11-1046-04 2x

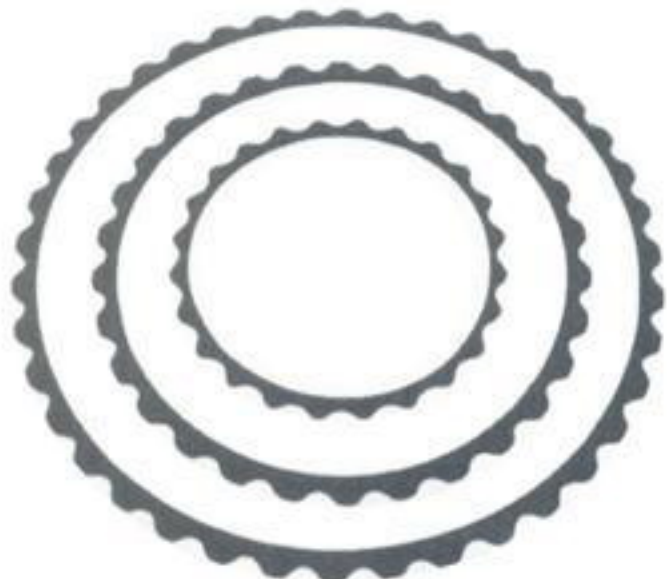

11-1050-00 Complete Set

Turner Warwick

1x 11-1050-18 18cm/7" Round
1x 11-1050-23 23cm/9" Round
1x 11-1050-30 30cm/12" Round
1x 11-1050-45 45cm/18" Oval
33cm/13"

Copper Blade



2x 11-1050-01
19 x 76 mm

2x 11-1050-02
57 x 89 mm

2x 11-1050-03
38 x 102 mm

2x 11-1050-04
57 x 114 mm



2x 11-1050-05
76 x 60 mm

2x 11-1050-06
51 x 38 mm



2x 11-1050-07
89 x 60 mm

2x 11-1050-08
114 x 60 mm



2x 11-1050-09
13 mm Deep

General Instruments

Probes

12



cm	In	1.0 mmØ	1.5 mmØ	2.0 mmØ	2.0 mmØ	12-0016-11	Watson-Cheyne	Fish
11.5	4 1/2"	12-0004-11	12-0006-11	12-0008-11				
13	5"	12-0004-13	12-0006-13	11-0008-13		12-0016-13	12-0020-13	
14.5	5 3/4"	12-0004-14	12-0006-14	12-0008-14	12-0012-14	12-0016-14		12-0024-14
16	6 1/4"	12-0004-16	12-0006-16	12-0008-16	12-0012-16	12-0016-16		
18	7"	12-0004-18	12-0006-18	12-0008-18		12-0016-18	12-0020-18	12-0024-18
20	8"	12-0004-20	12-0006-20	12-0008-20		12-0016-20		
25	10"	12-0004-25	12-0006-25	12-0008-25				



cm	In				Nelaton	Stacke 1.0 mm Ø	Brodie
10.5	4 1/4"					12-0040-10	
11.5	4 1/2"	12-0028-11					
13	5"	12-0028-13		12-0032-13	12-0036-13		
14.5	5 3/4"	12-0028-14	12-0029-14	12-0032-14	12-0036-14		
16	6 1/4"	12-0028-16		12-0032-16	12-0036-16	12-0037-16	12-0044-16
18	7"	12-0028-18		12-0032-18			
20	8"	12-0028-20			12-0036-20		

Of tin



12-0048-25 25 cm/10"
12-0048-30 30 cm/12"
12-0048-40 40 cm/15 3/4"

Plaster spatulas



12-0052-13 13 cm/5"
12-0052-14 14 cm/5 1/2"



Pelteson
12-0056-23
23 cm/9"



Fein
12-0058-28
28 cm/11"



Buie
12-0062-16
16 cm/6 1/4"

Fistula probes



Lockhart-Mummary
16.5 cm/6 1/2"



Fig. 1
12-0066-01



Fig. 2
12-0066-02



Fig. 3
12-0066-03



Fig. 4
12-0066-04



Pratt
21 cm/8 1/4"



12-0070-01



12-0070-02



12-0070-03



Universal

cm	in	1.2 mm \varnothing	1.5 mm \varnothing	1.7 mm \varnothing
12.5	5"	12-0074-12		
16	6 1/4"	12-0074-16		
18	7"	12-0074-18	12-0076-18	12-0078-18



Uckermann
12-0080-16
16 cm/6 1/4"



Jobson-Horne
12-0084-13 13 cm/5"
12-0084-18 18 cm/7"



Round Triangular

**Farrell
(Farrell-Lathbury)**

cm	in		●	▲
12	4 3/4"			
14	5 1/2"	0.9 mm \varnothing	12-0088-14	12-0089-14
16	6 1/4"	1.1 mm \varnothing	12-0088-16	12-0089-16
18	7"			



Round Triangular

	●	●	▲
	1.2 mm \varnothing	1.5 mm \varnothing	1.5 mm \varnothing
	12-0090-12	12-0092-12	12-0094-12
	12-0090-14	12-0092-14	12-0094-14
	12-0090-16	12-0092-16	12-0094-16
	12-0090-18	12-0092-18	12-0094-18

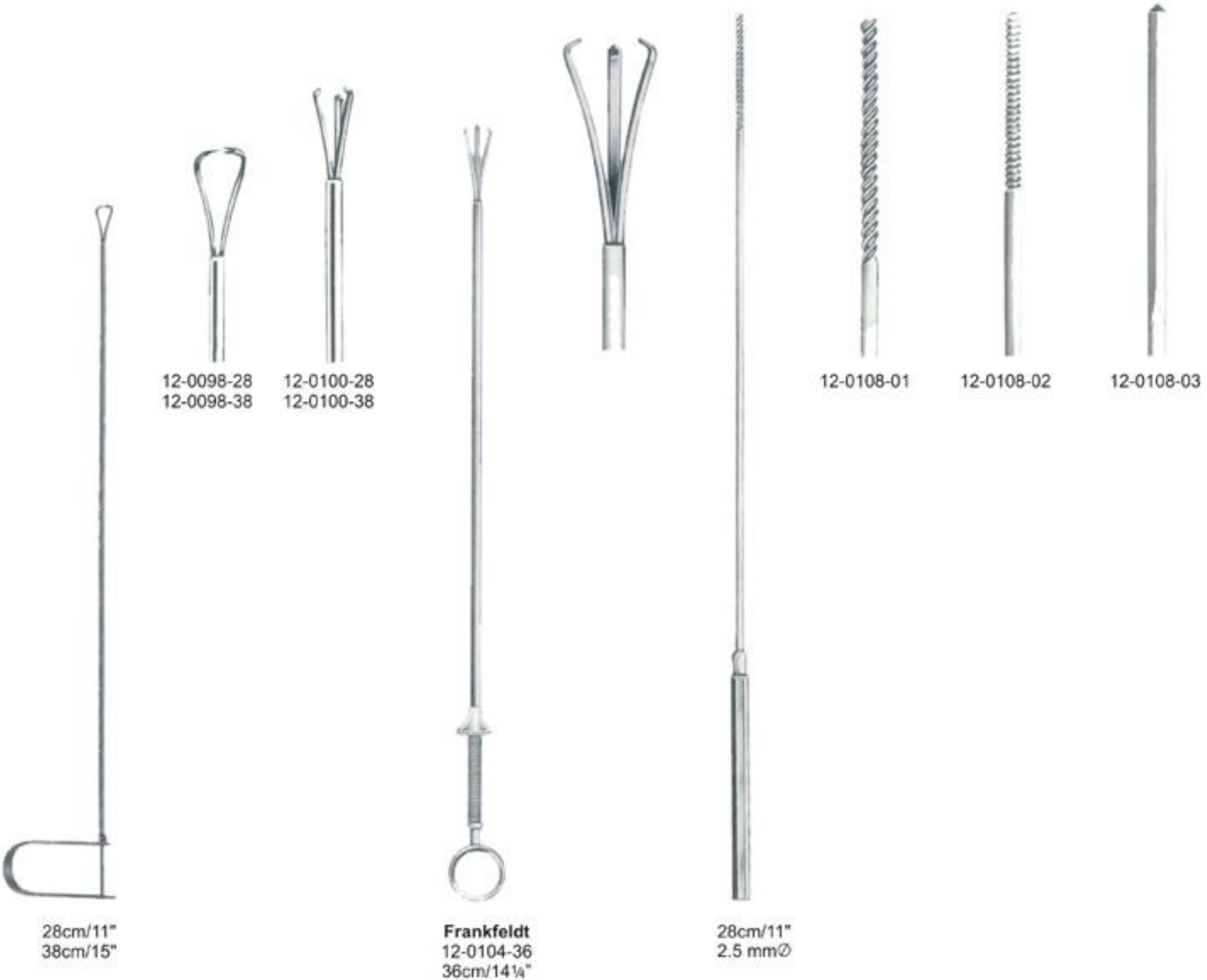

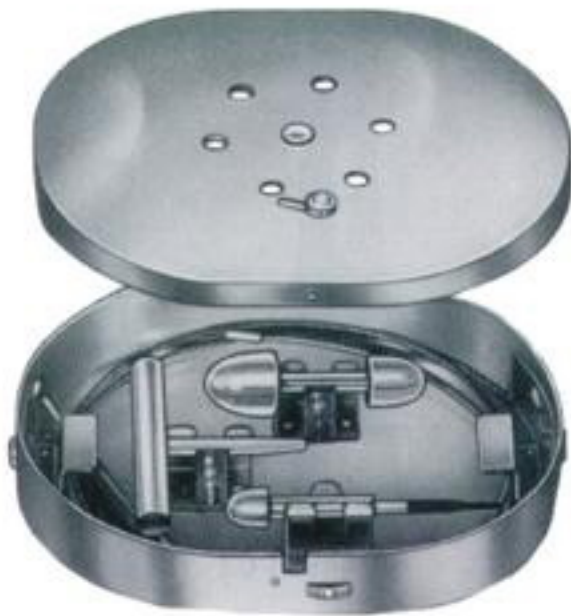

Nabatoff
 12-0112-00
 135x100x25 mm

Sterilizable



12-0112-01

12-0112-02

12-0112-20



12-0112-03
 3 mmØ

12-0112-06
 6 mmØ

12-0112-09
 9 mmØ

12-0112-12
 12 mmØ

12-0112-15
 15 mmØ

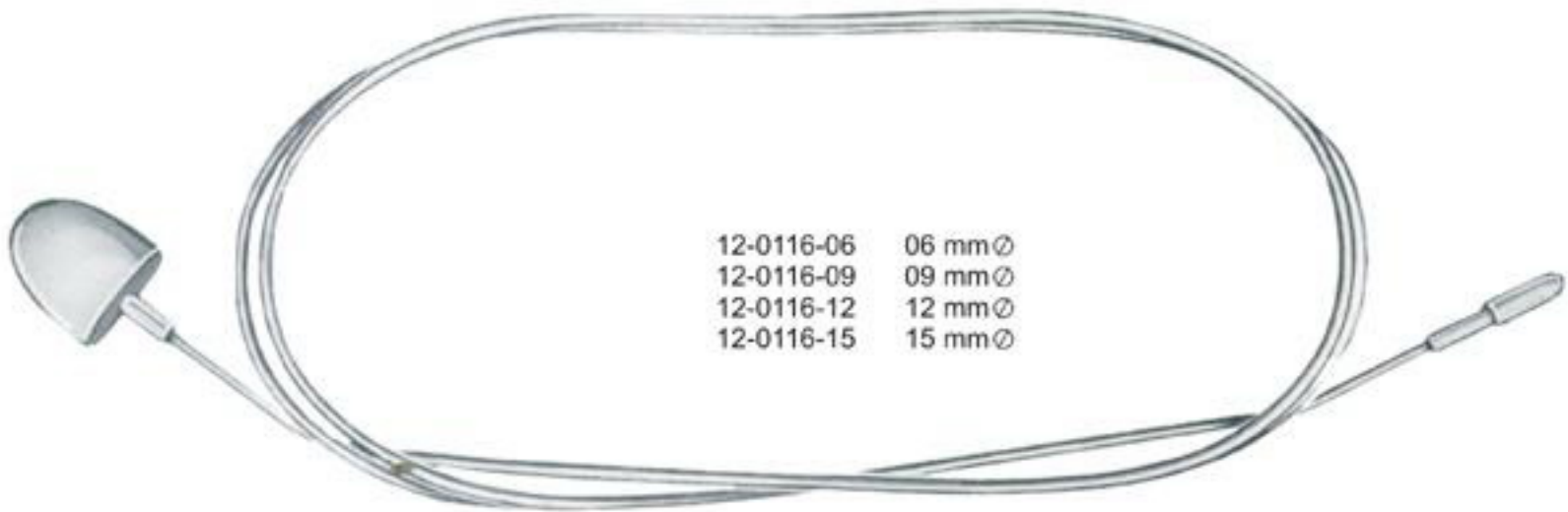

12-0116-06 06 mmØ
 12-0116-09 09 mmØ
 12-0116-12 12 mmØ
 12-0116-15 15 mmØ

Myers

Strippers



Probes for Varicose Veins

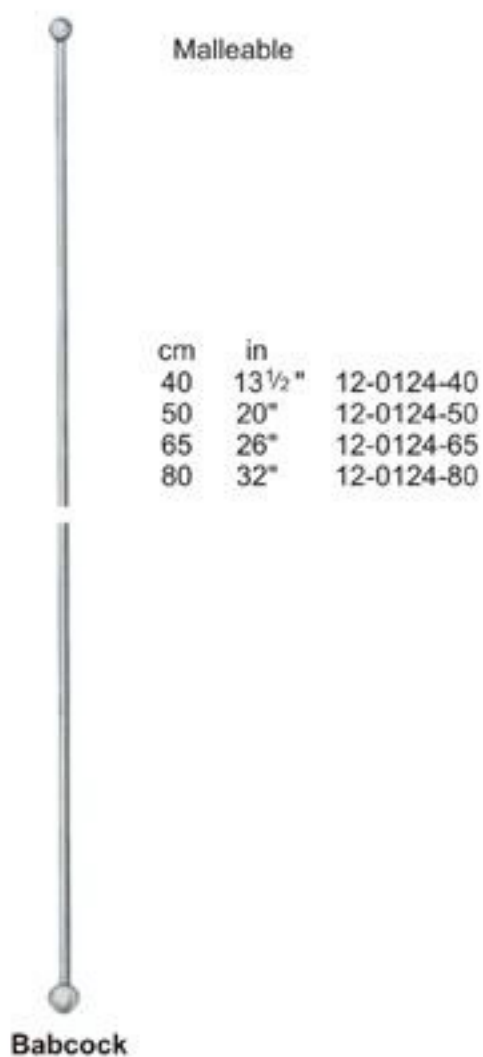

Vessel Irrigating Cannulas



Spatulas

